

# 2022 SUSTAINABILITY REPORT





# Contents

About the Report	5
Senior Management Messages	6
About Norm Holding	12
Economic Performance	18
Corporate Management	21
Awards and Achievements	45
Collaborations and Initiatives	54
Sustainability at Norm Holding	54
Stakeholder Relations	55
Sustainability Management	59
Sustainability Priorities	63
Future Matters	65
Goals	66

## Work Matters

Responsible Investments	74
Customer Expectations and Satisfaction	75
Product Quality and Safety	77
Operational Excellence	79
Supply Chain Management	80

## Planet Matters

Energy and Emissions Management	87
Water and Waste Management	90

## Technology Matters

R&D and Innovation	95
Digitalization	103

## Human Life Matters

Equal Opportunity and Diversity	110
Talent and Competency Management	112
Occupational Health and Safety	120
Social Activities	122

## Performance Indicators

Environmental Performance Indicators	126
Social Performance Indicators	126

GRI Content Index	129
-------------------	-----

# About the Report

We are pleased to share with you our third report, which includes our management performance, goals, and sustainability activities in line with our sustainability strategy, in keeping with our goal of updating and sharing our sustainability principles.

This report, prepared to present our 2022 performance to our stakeholders, explains our sustainability focus areas in detail under the headings “Work Matters”, “Planet Matters”, “Technology Matters” and “Human Life Matters”. Consulting services were provided by SUCSR Corporate Sustainability Consulting during the preparation of our report.

In the 2022 Sustainability Report, we share with you the performances and successful practices of Norm Holding and its affiliated companies regarding their activities in the period January 1, 2022 - December 31, 2022.

The report, prepared in compliance with the GRI Standards developed by the Global Reporting Initiative (GRI), also includes our vision to contribute to the United Nations (UN) Global Compact (UNGC) and Sustainable Development Goals signed by Norm Holding.

Norm Holding Sustainability Report of 2022 was prepared in two different languages, Turkish and English, and was not subject to external audit.

*You can forward any questions and comments regarding our reports and sustainability efforts to [sustainability@normholding.com](mailto:sustainability@normholding.com)*

# Senior Management Messages

**Fatih Uysal**  
Chairperson of the Board of Directors



## Dear Business Partners and Stakeholders,

As Norm Holding, we are glad to share our sustainability report with you, which clearly contains our social, environmental, and corporate governance efforts completed in 2022 in compliance with the United Nations Sustainable Development Goals.

Our past experiences have strengthened our commitment and increased our ability to overcome challenges. We continue to shape the future through these experiences. We carry out our activities by taking responsibility both for the future of our company and for a sustainable future.

We focused on new initiatives in 2022 by expanding our sectoral differentiation strategy, which has been in place since 2017, in order to improve company integration and efficiency. Through our investments,

we are continuously developing our renewable energy capacity to support our emission reduction targets that we plan to achieve by 2030. We take care to manage not only our own operations but also our entire supply chain in an environmentally sensitive manner.

When evaluating our investments, we consider their environmental and social benefits and focus on reducing the negative impact of our operations on the environment. We actively strive to minimize the negative environmental impact of all investments we make and plan by paying attention to environmental and social benefits.

We prioritize following and implementing technological developments and supporting innovation in every aspect of our business. As in previous years, in 2022,

we introduced many innovations in this field and developed our existing projects and implemented new ones. Utilizing our R&D background and experience, we are conducting important studies to improve our impact on the environment. We closely follow the advances in innovation and technology and keep ourselves constantly updated. In this way, we are a pioneer in the sector, offering the best service to our customers and aiming for even better. Thanks to our R&D studies and cooperation projects, we play a role in setting trends in the sector and shaping the future.

By addressing sustainability from a holistic perspective, we are on our way to making positive contributions in every field. In line with this goal, while we strive to reduce our environmental impact, we also aim to increase our social impact through our human resources practices, occupational

health and safety measures, corporate social responsibility projects and various supports.

Thanks to our innovative mindset, keeping customer satisfaction at the highest level by offering solutions tailored to their needs is at the top of our list of priorities. Anticipating the needs of the future, we work on sustainable and environmentally sensitive projects. In order to achieve our growth targets, we continue our overseas investments with determination and share our technological know-how with our customers.

We focused on Norm Digital, which offers digital transformation consultancy and culture; Norm Additive, where we aim to be the sector leader in additive manufacturing; Norm Forging in hot forming; and Nordes, which will operate in the food sector, a new

sector breakthrough.

With the projects and processes we successfully completed in 2022, we address corporate risk management on a sustainable basis. In 2023, we will continue to expand corporate risk management and adopt the principle of continuous improvement to create a sustainable corporate structure.

In line with our goal of continuous improvement, we are committed to move forward in the area of good governance. We focus on improving ourselves and building a more solid foundation in line with the assessments made by independent organizations.

We are proud to have successfully completed 2022 with satisfactory results achieved through our sustainability efforts. Believing that 2023 will be filled with the

same success and efficiency, we continue our sustainability journey.

I would like to extend my sincerest thanks to all our stakeholders, especially my colleagues, for their contribution and support to our performance in 2022.

# CEO's Message



**Nedim Uysal**  
CEO – Vice Chairperson



## Dear Business Partners and Colleagues,

As Norm Holding, we continued to invest in different sectors and existing working areas in 2022 without compromising our healthy growth approach. With our new investments, we increased the number of companies within Norm Holding to 23 and the number of our employees to over 4.000.

Despite the negative developments all over the world, we managed to increase our consolidated turnover by 33% compared to 2021 to 466 Million Euros. Thanks to our healthy financial management and strong balance sheet structure, we earned an A+ credit rating from JCR Credit Rating Company in our subsidiaries.

We are proud to be the 203rd company in Turkey to invest the most in R&D. At the same time, we are successfully positioned

in the ISO 500 and Second 500 lists with our 4 different companies operating in Izmir and Salihli under the Norm Fasteners and Norm Coating brands.

In our 49th year, we aim to maintain our sectoral differentiation strategy without compromising our healthy growth principle. With our vision of providing quality products and services to our customers, we aim to further strengthen our leadership in the sector.

We aim to build on these achievements in the future by continuing to pursue our sustainable growth ambitions and tackling the challenges we face.

As Norm Holding, we will continue to offer the most efficient environment in 2023 in terms of developing and rewarding the talents of our employees, who are our most important stakeholders, by adopting

the emphasis of “Human Life Matters” since the day we were founded.

We pursue a fair labor policy in order to strengthen and build the talents of our employees and we offer this policy with equal care to our employees in all our fields of activity.

We consistently continue to be a preferred employer brand by ensuring employee loyalty through ongoing dedication, understanding and commitment.

In 2023, we will continue our efforts to develop the skills of our employees and reward them. We will continue to provide the best environment for our employees by establishing the principle of human value on a fair basis in every field of activity.

We care about the satisfaction and loyalty

of our employees, and we are constantly improving our labor policy towards these valuable stakeholders and increasing our efforts to become a preferred employer brand. With our values based on the Human Life Matters principle, we will strive to support the success of our employees and provide them with opportunities in 2023.

In line with Human Life Matters, we will continue to move forward while strengthening and developing our sustainability way of doing business together with our stakeholders, respecting the environment and adding value to society.

In 2021, the Sustainability Committee, which assumed responsibility for sustainability efforts at Norm Holding and its companies, will continue its work with the same determination in 2023.

We are reaping the fruits of our efforts in sustainability; we crowned our achievements by winning the “TAİDER North Star Award” and the “Silver Medal” at Ecovadis.

In 2022, we have experienced sustainable positive situations and now we are striving to make sustainability more widespread and integrate it more into Norm Holding culture by implementing our new projects together with our action plans.

We will continue our training sessions to reinforce our achievements in the field of sustainability and to adopt this culture throughout the company. By demonstrating the importance we attach to human life and the environment at every step, we will continue our more sustainable and value-creating way of doing business for the future.

Within the framework of our “Work Matters” business approach, in 2023 we will focus on managing sustainability end-to-end in the supply chain and assessing and developing our suppliers on sustainability issues. We will maintain our goal of becoming a global company with our “Responsible Purchasing Policy”. Our working groups established by the Sustainability Committee will continue their work by qualifying action plans in the fields of “R&D and Innovation”, “Environment”, “Digital Transformation”, “People and Society” and “Corporate Governance”.

Norm Holding aims to be a company that goes beyond using technology, creates trends in production processes and continuously develops to ensure digital transformation. We will continue our efforts to advance in automation and continuously adopt new technologies.

In 2023, we intend to build on our global success by moving forward with qualifying action plans developed by our working groups in areas such as sustainability, R&D, environment, digital transformation, people and society, and corporate governance.

I would like to want to express my sincere gratitude and respect to my valued colleagues and business partners who helped to our smooth passage through this extremely difficult moment for our country and the entire world.

# Message from the Chairperson of the Sustainability Committee and Board Member

**Duygu Uysal Simrooğlu**  
Sustainability Committee  
President -Member of Board of  
Directors



## Esteemed Stakeholders,

As Norm Holding, I am pleased to share with you our third sustainability report, which includes details about the sustainability activities we carried out in 2022.

Since 2020, we have regularly published sustainability reports to clearly share the effectiveness and impact of our business with all our stakeholders. At the same time, we continue to make progress toward ensuring that our actions are measured and traceable in accordance with international standards.

With our Work Matters approach, we strive to increase employee happiness and create a sustainable tomorrow by focusing on the future of our world and our organization, in line with our mission to create value for our stakeholders and our vision to focus on

excellence together with our employees.

With our Planet Matters approach, we aim to create a future that is resilient to the negative impacts of climate change by limiting the global average temperature increase to 1.5°C, which is the main objective of the Paris Climate Agreement. To accomplish this goal, we support our efforts in renewable energy to improve low-carbon development and adaptation potential. In this direction, we invested a total of 4 million Euros in “production track renewal”, “energy efficiency” and “renewable energy”. In this framework, we are moving forward step by step with the projects we have realized and plan to do in the future.

According to the results of our carbon footprint measurement studies, we calculated our emissions in 2022 and

analyzed our environmental impact throughout the reporting period. In the context of tackling the climate crisis, we have set a target to reduce our Scope 1 and Scope 2 emissions by 50% by 2030, in line with the EU Green Deal. By 2050, we aim to reach the “net zero” target.

The focus of our Human Life Matters and Technology Matters value approach is not only on commercial gain, but also on conducting correct and honest activities in accordance with ethical values. The safety of our colleagues continues to be our top priority. We continue to strive for zero accidents in all of our business activities by boosting occupational safety initiatives and investing in safety technologies. We are proud to implement Norm Holding’s vision of business ethics at every stage of our business processes. 42,654 hours of Occupational Health and Safety training

reflects the importance we attach to the development of our employees and suppliers.

In 2022, we invested 70 million TL in environmental investments and 112 million TL in R&D and Innovation projects.

With our Human Life Matters approach, while we continue to create value for our country with more than 4 thousand employees, we also continue our efforts to contribute to social development by focusing on the sustainability of the world’s resources, diversity, and inclusion.

On Gender Equality, we continue our mission to ensure equal participation of individuals in economic and social life with determination. We are focused on taking steps and moving forward towards this goal. We are proud to be one of the leading

companies in our sector with 23.1% women in managerial positions and 35.6% female office employees.

Today, we are all in an era of change, where the empowerment, support and sustainable development of local communities is more critical than ever. In all our operating regions, in 2022, as Norm Holding, 80.5% of payments to suppliers in our industry group and 88.0% of payments to suppliers in our trade group were made to local suppliers. In this way, we aim to support local ecosystems and promote sustainability.

As Norm Holding, we are always ready to move forward under the guidance of science and support sustainable development. To this end, we collaborate with our customers, suppliers, subcontractors, and business partners to develop practices that will set

an example for industry representatives. Our goal is to contribute not only in the sectors we operate in, but also by actively participating in all platforms that promote sustainability.

We are committed to rigorously measuring our progress and increasing transparency about our performance. Our goal is to promote a culture of accountability and make sure that our actions are consistent with our values as well as the demands and requirements of our stakeholders. With this in mind, we will continue to update our strategy and roadmap to improve our company and our employees in the future, as we have done in the past, and work to reduce the environmental impact of our operations and products in our “Future Matters” sustainability journey.

We would like to thank our valuable

colleagues, customers, suppliers, business partners and all our stakeholders for their valuable contributions.

# About Norm Holding

## 49 Years of Success...

Since the day we were established as Norm Holding, we have worked to be a leader in the industry, and in the 49 years we have been in business, we have had a lot of success.

Our actions are guided by a vision that is full of accomplishments and awards, constantly evolving without sacrificing quality, and produced using the most recent technologies. The automotive main and sub-industries, as well as the spare parts, white goods, electronics, technology, furniture, construction, and machinery sectors, are where we primarily conduct our business on a national and international level. With our production capacity, quality, creative human resources approach that we built on our values, and our superior technology that we develop every year, we have managed

to become the top business in our nation in the fasteners sector, which is our locomotive power.

We are proud that our Norm Holding companies are among the top 500 industrial enterprises in Turkey. In 2022, with the projects and companies we developed in 2021, we are on our way to becoming a holding that provides sustainable growth in line with our goal of becoming a leader in the sector, which we have adopted and realized from day one.

“ By adapting to the requirements of the era, we add value to our national industry and continue to grow. ”

## Our Mission

To be a global solution partner that creates value for its stakeholders, is always trusted and preferred.

## Our Vision

To be a global company that pursues excellence together with its employees.

## Our Values



We make a difference for our customers



We believe in team power



We act fairly and respectfully



We add value to society and the environment



We constantly improve our norms and ourselves

## Norm Holding – Vision 2025

FINANCIAL BUSINESS OUTCOMES	SUSTAINABLE PROFITABLE GROWTH	COST MANAGEMENT AND RESOURCE EFFICIENCY	
	CUSTOMER (PARTNER) VALUE PROPOSITION		
CUSTOMER / PARTNER	BUSINESS PARTNERS	SOCIETY	
	BRAND AWARENESS AND IMAGE	CORPORATE REPUTATION AND SOCIAL INFLUENCE	
PROCESSES (FOCUS AREAS)	MARKET- AND CUSTOMER-ORIENTED	R&D AND INNOVATION	OPERATIONAL EXCELLENCE
	SUSTAINABILITY		
INTANGIBLE ASSETS	HUMAN RESOURCE AND COMPETENCY	CORPORATE CULTURE AND ORGANIZATIONAL EXPERIENCE	IT AND INFORMATION GAIN TECHNOLOGY AND DIGITAL TRANSFORMATION

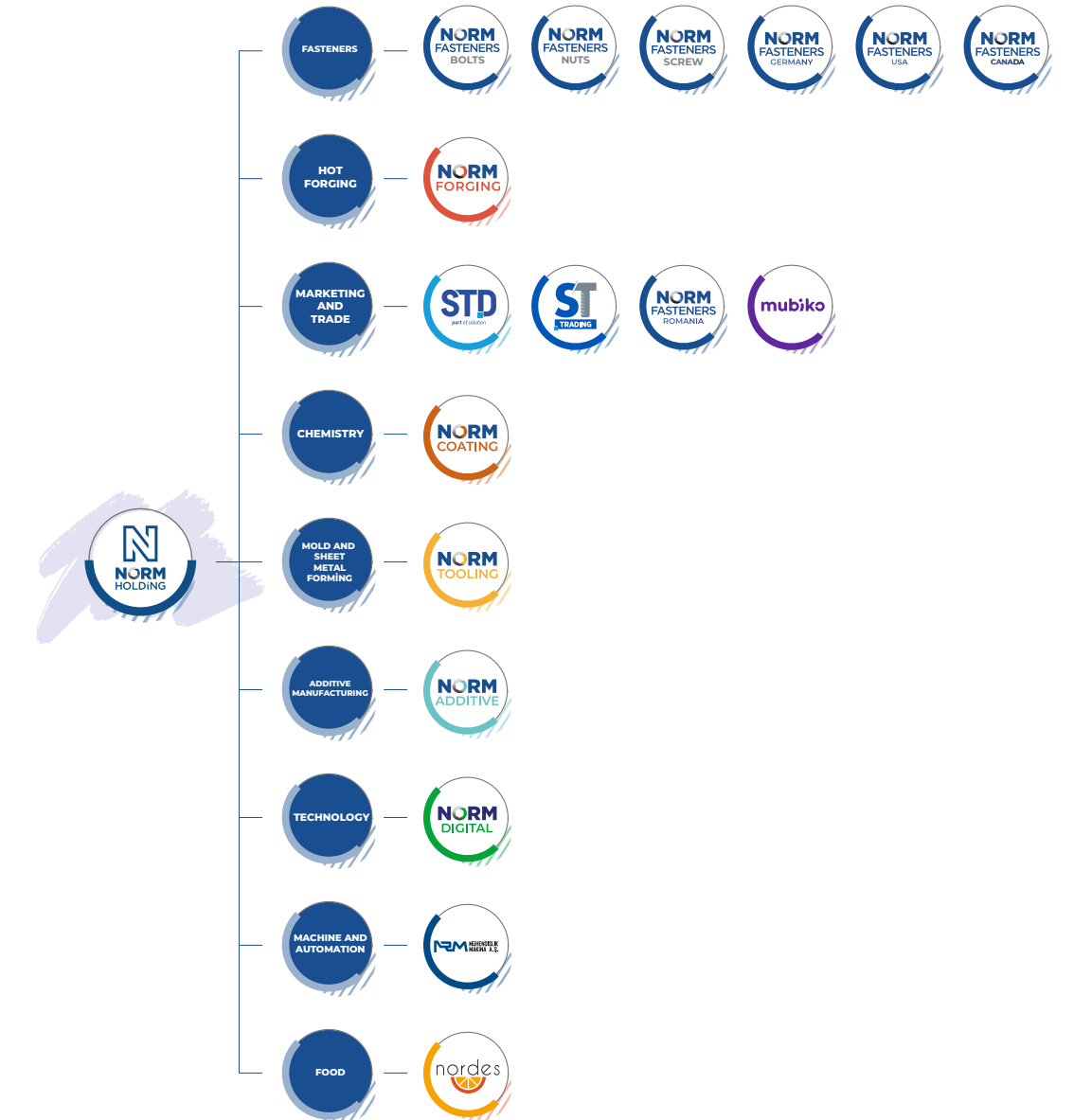



# Norm Holding at a Glance

Year of foundation **1973**

Number of countries of operation **9**

More than **4000** employees

Services in **9** countries

**23** companies

**18** production centers with high production capacity

**15** logistics centers for efficient and fast logistics processes

**5** R&D and Design Centers innovative solutions

Exports to more than **50** countries

Registered **13** patents, **6** utility models, **6** industrial designs

**70.000.000 TL** environmental investment

More than **110.000.000 TL** R&D and Digitalization investment

**12** Awards

More than **2200** customers across all our companies

**100%** recycling of non-hazardous waste

**13,500** hours of additional labor with Normie

**23.1%** rate of women working in managerial positions

**%35,6** rate of female office employees

**42.654** hours of Occupational Health and Safety training

# Milestones of Norm Holding

Norm Holding, 1973 yılında çift vuruşlu bir makine ile başlayan yolculuğunu, bugüne dünya ile rekabet eden, kaliteden ödün vermeyerek gelişen, teknoloji ile üreten, başarılar ve ödülleri dolu bir vizyona dönüştürmüştür.

Lokomotif gücü olan bağlantı elemanları sektöründe Norm Holding; üretim kapasitesi, kalitesi, değerleri üzerine inşa ettiği yenilikçi insan kaynakları perspektifiyle ve her geçen yıl geliştirdiği teknolojisiyle Türkiye'nin lider kuruluşu olmayı başarmıştır.

Norm Holding, 4.000'den fazla çalışanı, 5'i yurt dışında olmak üzere toplam 23 şirket ve 18 üretim merkezi ile ulusal ve uluslararası pazarlarda, otomotiv ana ve yan sanayi başta olmak üzere yedek parça, beyaz eşya, elektronik, teknoloji, mobilya, inşaat ve makine sektörlerinde faaliyet göstermektedir. Norm Holding, ihracat yaptığı ülke sayısını 50'nin üzerine çıkarmıştır.

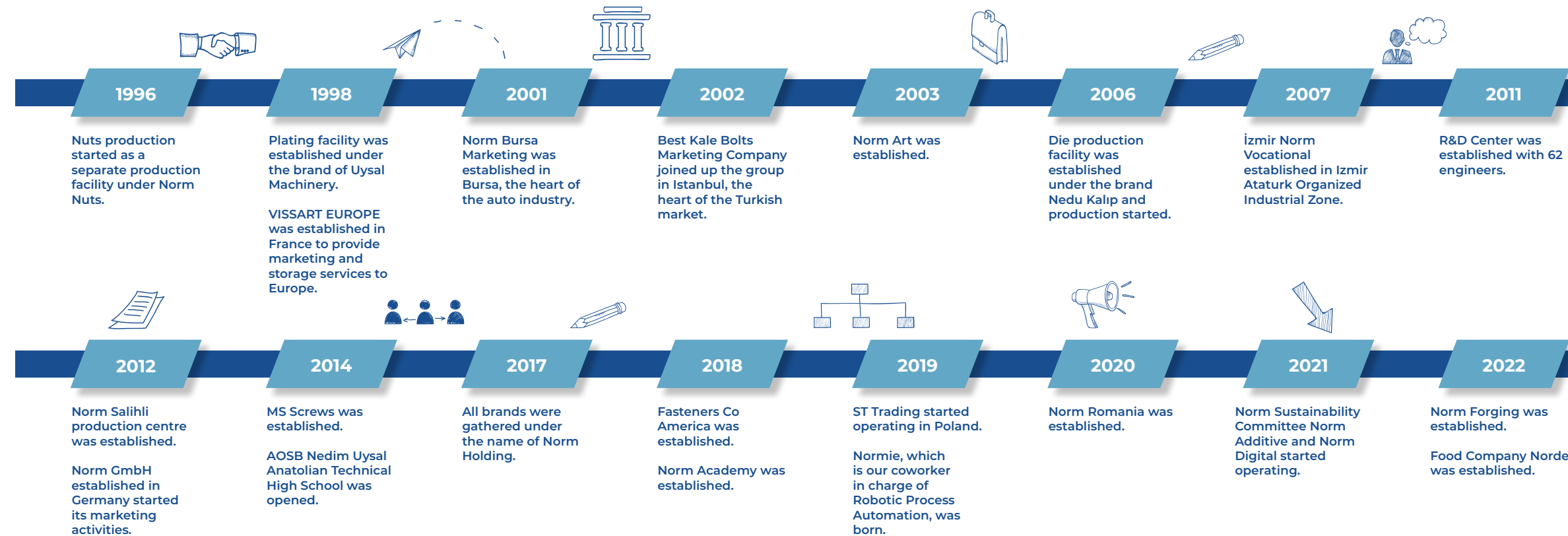

# Economic Performance

70 million TL environment investment

112 million TL investment in R&D, Innovation and Digitalization projects

In 2022, we stayed true to our healthy growth target and invested in different sectors and existing areas. By establishing Norm Forging in hot forging and Nordes in the food sector, we increased the number of companies within Norm Holding to 23 and the number of employees to over 4,000. In 2022, we achieved a 33% increase in consolidated turnover compared to the previous year, reaching EUR 466 million. With our sound financial management and strong balance sheet structure, we crowned our success by receiving an A+ credit rating from JCR Credit Rating Company in our subsidiaries.

In 2022, we did not only focus on financial success, we took an environmental and community-oriented approach. We acted with the "Planet Matters" approach and realized an environmental investment of

approximately 70 million TL in 2022.

We remain committed to sustainable development and ethical values. The increase in our revenues and the investments we make are our motivation to achieve even greater success in the future. We will keep moving forward and continue our efforts in R&D, innovation, and social responsibility to strengthen our leadership in the industry. In parallel with the increase in our revenues, we invested 112 million TL in R&D, innovation, and digitalization projects. As Norm Holding, while we invested 1.2% in R&D in our Norm Fasteners Bolts company in 2021, we increased this rate to 2.01% in 2022. We are proud to be the 203rd company in Turkey to invest the most in R&D.

## KONSOLİDE

### CONSOLIDATED NET SALES

Million €

466 Million €

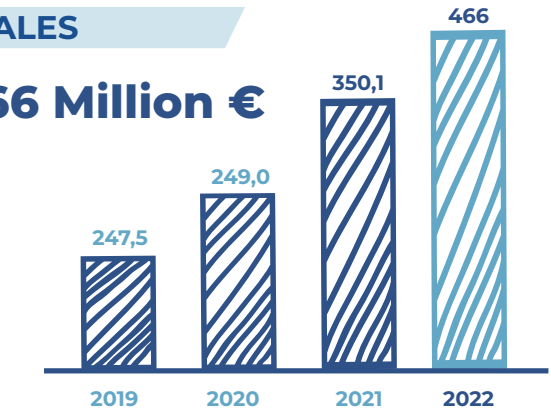

### Norm Fasteners Bolts R&D Inputs

R&D / Sales Ratio of Norm Fasteners - Bolts (%)

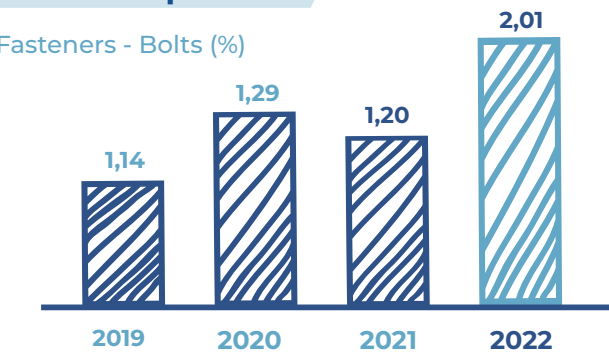

### CONSOLIDATED CAPEX / Million €

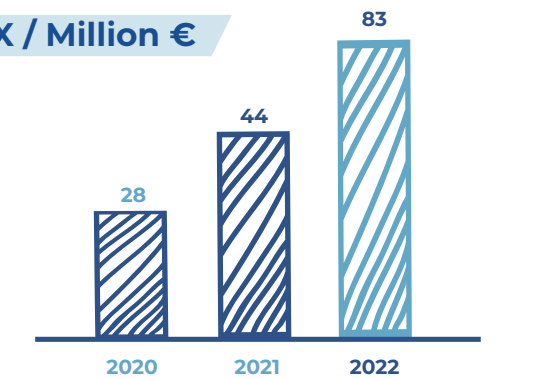

# Corporate Management

We take a responsible, accountable, ethical, and transparent approach to corporate governance. We care about the interests of the stakeholders with whom we interact in every area in which we conduct business. Our corporate governance approach ensures that we adopt sustainability as a fundamental principle.

Thanks to our management structure, we monitor risks and opportunities, actions taken and targets set at the level of the Board of Directors. We believe that performance indicators that are not limited to financial results should include issues such as climate change and supply chain, in addition to areas where the performance of senior management and employees is measured. In this way, we aim to make successful progress in all areas, including our sustainability goals.

The Board of Directors is the highest governance body charged with carrying out tasks like establishing corporate

governance, defining strategic goals, determining the human and financial resources required, monitoring management performance, and making sure that all of our operations comply with established laws, internal rules, and policies in the holding and its subsidiaries. As the company's highest governing authority, the Board of Directors, comprised of experienced and capable members, assumes these tasks, and makes decisions about general management, strategic direction, and long-term performance. It is also in charge of corporate sustainability, risk management, performance evaluation, accountability, and corporate compliance. Carrying out its activities in order to protect the interests of the company and the interests of its stakeholders, the Board of Directors aims to act in a transparent, fair, and ethical manner.

It shapes the company's future by taking strategic decisions and adopting the highest standards of governance with the

aim of supporting the company's success and sustainable growth.

The senior management of Norm Holding includes 6 senior executives who have proven their expertise and professional competencies in various fields. The ratio of members of the Board of Directors who are not shareholders of the company is set at 40% in 2022. In this way, the company aims to ensure diversity in management by increasing the number of independent members.

While the rate of female members on boards of directors in Turkey will increase to 17.5 percent in 2022, :

- Rate of women working in managerial positions 16.7%
- Rate of women working in the Supervisory Board: 25%
- Rate of Women in the Executive Board: 33.3%

The Board of Directors focused on the targets set at the beginning of 2022

and prepared an efficiency report and presented it to shareholders at the end of the year. A total of 11 Board meetings were convened in 2022.

During the period 01 01 2022 - 31 12 2022; there were no lawsuits filed against the members of the Board of Directors and employees due to practices contrary to the provisions of the legislation, and there were no administrative or judicial sanctions.

You can find detailed information about Norm Holding's corporate governance structure in the Norm Holding Annual Report of 2022 published on our website. Norm Holding Corporate Governance Compliance Report is available here.

# Structure of the Board of Directors

In Norm Holding and its subsidiaries, company management is regulated by the Articles of Association. Company affairs are effectively managed by the Board of Directors. The first non-shareholder member joined the Board of Directors in 2020, and other non-shareholder members joined the Board in 2021 and 2023.

Board meetings were expanded to include six Board members, one Board Advisor and three senior executives. This structure makes it possible to receive productive and constructive contributions and make quick, rational decisions. In this way, the management of the company is carried out effectively.

During the period 01 01 2022 - 31 12 2022; there were no administrative or judicial sanctions imposed on the company or the members of the Board of Directors due to practices contrary to the provisions of the legislation.

First, Last Name	Position	Term of Office	Executive/ Shareholder	Committees	Other Positions
Mehmet Fatih UYSAL	Chairperson of the Board of Directors	22 April 2021 15 April 2024	Non-executive Shareholder	-	BoD Chair and Member in companies inside & outside the Holding
Nedim UYSAL	CEO – Vice Chairperson	22 April 2021 15 April 2024	Executive Shareholder	Investment Committee	BoD Chair and Member in companies inside & outside the Holding
Duygu UYSAL SİMROOĞLU	Member of the Board of Directors	22 April 2021 15 April 2024	Non-executive Shareholder	Sustainability Committee	-
Muhittin BİLGET	Member of the Board of Directors	22 April 2021 15 April 2024	Non-executive Non-shareholder	Audit Committee Corporate Governance Committee Early Detection of Risk Committee Investment Committee	BoD Member in companies inside & outside the Holding
Ceyhun ARAZ	Member of the Board of Directors	22 April 2021 15 April 2024	Non-executive Non-shareholder	Corporate Governance Committee Audit Committee Sustainability Committee	BoD Member in companies inside & outside the Holding
Mustafa DOĞRUSOY	Member of the Board of Directors	27 February 2023 15 April 2024	Non-executive Independent Non-shareholder	Corporate Governance Committee Audit Committee Early Detection of Risk Committee Sustainability Committee	BoD Member in companies inside & outside the Holding
Erkut ULUDAĞ	Advisor to the Board of Directors	-	Advisor	Early Detection of Risk Committee Investment Committee	-

# Board Members

## 1 Mehmet Fatih Uysal

Chairperson of the Board of Directors

Fatih Uysal, graduated from Dokuz Eylül University, Faculty of Economics and Administrative Sciences, Department of Business Administration in 1983, started his professional career in 1982 as General Director in STD, one of Norm Holding companies. Becoming Deputy Chairperson of Board of Directors in 1995 in Norm Fasteners Bolts company, Fatih UYSAL has been continuing his career as Chairperson of Board of Directors of Norm Holding since 2013. Uysal is a member of the Board of Directors of

 Mehmet Fatih Uysal

## 2 Nedim Uysal

CEO – Vice Chairperson

Nedim Uysal, who graduated from Izmir American College, received his bachelor's degree from Department of Economics at Michigan State University. Uysal, who did internship in different business units of Norm Fasteners Bolts company

 Nedim Uysal

## 3 Duygu Uysal Simrooğlu

Member of Board of Directors – Chair of Sustainability Committee

Graduating from Izmir American College in 2010, Duygu Uysal Simrooğlu completed her bachelor's degree in Drama and Arts at New York University. Since 2018, Simrooğlu has been continuing her contemporary dance education and has been professionally involved in various dance genres and visual arts. In September 2023, Simrooğlu will be the

 Duygu Simrooğlu

TAYSAD, BESİAD and Aegean Exporters' Associations, a member of the Coordination Board of the IBB Izmir Economic Development Board, a member of the Executive Board of the Turkish Education Foundation, a member of the Board of Trustees of the Izmir Chamber of Commerce Education and Health Foundation, a member of the Union of Chambers and Commodity Exchanges of Turkey and a member of TÜSİAD, TİM, TAİDER, KALDER, ESİAD, EGİAD, Salihliler Culture and Solidarity Association.

since his middle school years, started his professional career in Norm Holding right after graduating from the university. Nedim Uysal currently serves as CEO and Deputy Chair of the Board of Directors at Norm Holding.

producer and artistic director of the Feminine dance project choreographed by Cansu Ergin, which will be staged within the scope of IKSEV Izmir European Jazz Festival and in addition to her current position as a Member of the Board of Directors of Norm Holding, she also leads the company's sustainability activities as the Chair of the Sustainability Committee.

## 4 Muhittin Bilget

Member of the Board of Directors

Muhittin Bilget graduated from Ankara University Faculty of Political Sciences and completed his master's degree in Economics at Vanderbilt University in the USA. Between 1979 and 1993, Bilget served as the Republic of Turkey Prime Ministry Sworn-in Bank Auditor and Deputy Chairperson of the Board of Sworn-in Bank Auditors. He served as the Economic and Commercial Counselor at the Embassy in Ottawa (Canada). Having been working as a senior

## 5 Ceyhun Araz

Member of the Board of Directors

Ceyhun Araz received both bachelor's and master's degrees in Industrial Engineering at Dokuz Eylül University. He then obtained his Ph.D. degree in Supply Chain Management from the same university. In 2010, he received the title of Associate Professor and established the Department of Industrial Engineering at Manisa Celal Bayar University. Having over 40

 Ceyhun Araz

manager in the private sector since 1996, Muhittin Bilget possesses Certified Public Accountant and Independent Auditor license. Bilget is currently the Deputy Chairperson of the Board of Directors of Salihli Organised Industrial Zone, a member of the Izmir Economic Development and Coordination Board, and the Chairperson of Roundtable for Economy, Revenue and Finance at ESİAD.

academic publications and over 1,500 international citations, Araz received the title of Associate Professor in the field of Industrial Engineering in 2018. Serving as a board member in various industrial and technology companies, he has been working in Norm Holding since 2015.

## 6 Mustafa Doğrusoy

Member of the Board of Directors

Mustafa Doğrusoy studied both Business at Istanbul University and a Computer Engineering master's degree at Yıldız Technical University simultaneously and graduated with an MBA degree. As a strategy and investment consultant, he advises companies on issues such as management, organization, strategic planning, institutionalization, and corporate culture. As an adjunct lecturer, Doğrusoy lectures in graduate and doctoral programmes of universities and

 Mustafa S. Doğrusoy

## 7 Erkut Uludağ

Advisor to the Board of Directors

Erkut Uludağ is a graduate of Kadikoy Anatolian High School as well as the Civil Engineering department of ITU. He completed his master's degree education in Civil Engineering Department of Michigan University in USA in the year of 1993 and his MBA Master's in Business Administration degree in 1998. Starting his career in the automotive industry in the USA in 1993, Uludağ worked in the Chicago office of the global consulting firm Kearney between 1997 and 2004, providing consultancy services to global companies for operational and cost improvement,

 Erkut Uludağ

continues to work as a member of the Advisory Board of a Foundation University. He was a member of the Board of Management of the Corporate Governance Association of Turkey between the years of 2015–2019. In accordance with the Capital Market legislation, he has worked as a member of the Independent Board of Directors in various corporations in the stock market since 2012. Since 2020, he has been serving at Norm Holding.

mergers, strategy development and private equity funds for their sectoral investments. Between the years of 2004 and 2012, worked as an executive of Roland Berger strategical consultancy corporation, Uludağ provides consultancy services in the fields of acquisitions, mergers, and strategy development with EU Corporate Consultancy, which he established in 2013. Uludağ, who has board memberships in various industrial companies, has been serving as Norm Holding Board of Directors Advisor since 2018.



# Organizational Structure

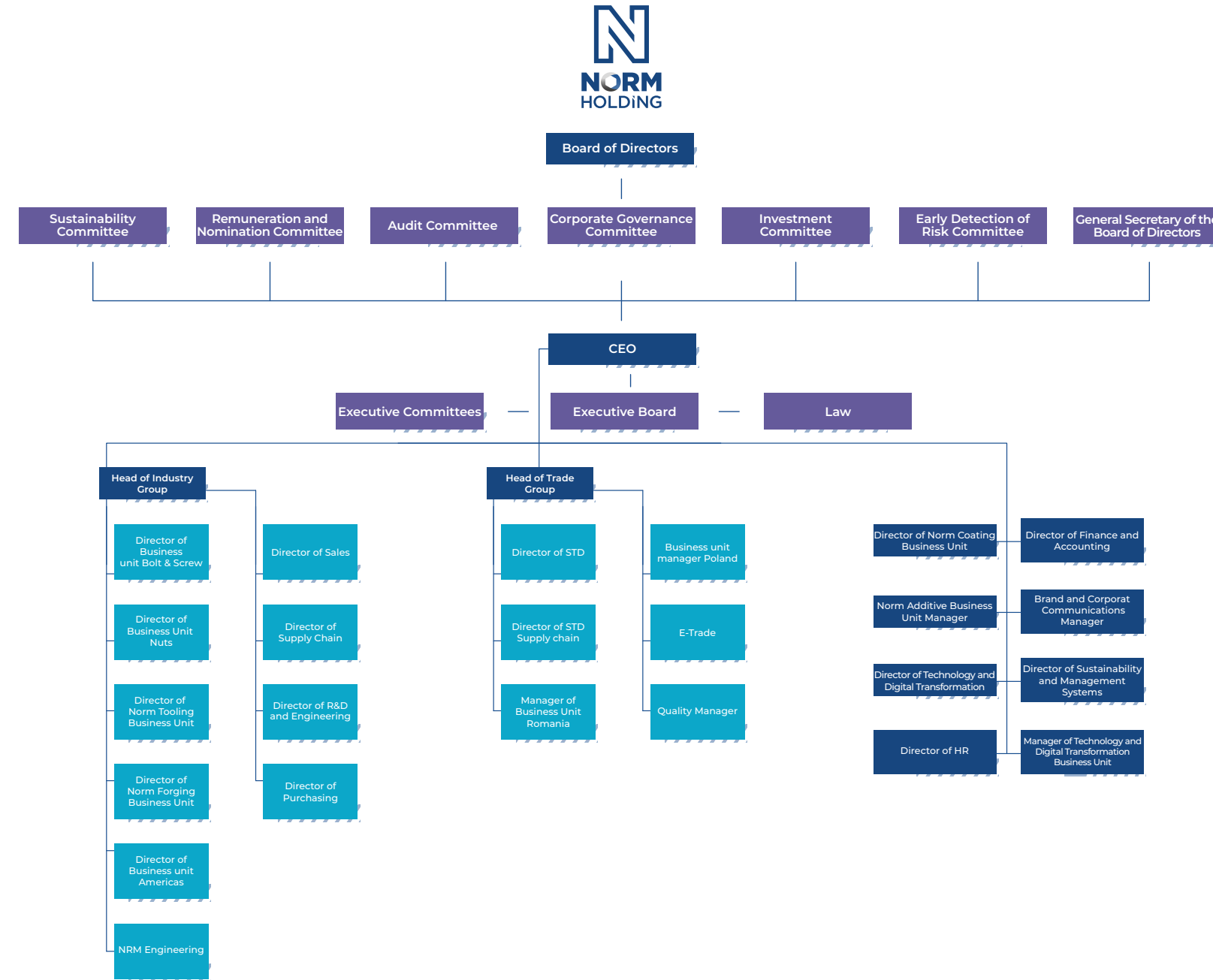

# Committees within the Board of Directors

Within the scope of Corporate Governance Principles, there are 6 committees in total within the Norm Holding Board of Directors.

- Audit Committee
- Corporate Governance Committee
- Remuneration and Nomination Committee
- Early Detection of Risk Committee
- Sustainability Committee
- Investment Committee

Committees act within the framework of their powers and responsibilities and advise decision-making mechanisms. However, the final decision and responsibility belongs to the Board of Directors.

## Audit Committee

Norm Holding Audit Committee		
First, Last Name	Position in Committee	Position in Norm Holding
Muhittin Bilget	Chair	Member of the Board of Directors
Ceyhun Araz	Member	Member of the Board of Directors
Mustafa Doğrusoy	Member	Member of the Board of Directors
Beste Demir	Member	General Secretary of the Board of Directors and Legal Counsel

\*Current members at the date of publication of the report are listed.

It is responsible for the selection of the independent audit firm that audits the accuracy, transparency and compliance of the financial statements and other financial information with the legislation and international accounting standards, and for the preparation of the contracts and initiation of the independent audit process. The Committee ensures coordination with the work of the independent audit firm at every stage and notifies the opinion of the independent audit firm to the Board of Directors in writing.

The Audit Committee convenes at least once every two months. The frequency of meetings can be increased depending on the effectiveness of the work and the intensity of the agenda. The committee also monitored the work on the Enterprise Risk System. In 2022, Enterprise Risk Management was initiated in three subsidiaries and it was planned to be extended to other group companies in 2023. The Audit Committee convened six

times in relation to its activities in 2022 and the Board of Directors was briefed on the committee's work each quarter.

The Audit Committee submitted its activity report regarding the activities in 2022 to the Norm Holding Board of Directors on March 01, 2023, and it was accepted and resolved by the Board of Directors.

## Internal Control and Internal Audit

With Internal Control activities, we aim to provide independent and objective assurance on the effectiveness of activities, reliability of financial data and compliance with legislation. Internal Control activities are evaluated by our Internal Audit Department. The Department evaluates management and control structures through risk analyses and reports findings and recommendations for action to the Audit Committee. Risk ratings are made by auditors taking into account the impact and likelihood of the risk. Risk management is based on early detection and centralized

# Committees within the Board of Directors

management of risks that may jeopardize the company's existence. The Board of Directors is informed when necessary.

## Corporate Governance Committee

Norm Holding Corporate Governance Committee		
First, Last Name	Position in Committee	Position in Norm Holding
Mustafa Dođrusoy	Chair	Member of the Board of Directors
Muhittin Bilget	Member	Member of the Board of Directors
Ceyhun Araz	Member	Member of the Board of Directors
Filiz Ergin	Member	Executive Committee Member / Human Resources Director
Bengisu Ertem	Member	Strategy and Business Development Specialist

\*Current members at the date of publication of the report are listed.

It reviews and evaluates systems and processes for the implementation of methods and practices that will improve the Company's performance and makes recommendations to the Board of Directors. It proposes to the Board of Directors the committees that should be established within the company in accordance with good governance.

The Committee convenes at least once every two months. The frequency of meetings may be increased according to the committee's decision based on the effectiveness of the work and the intensity of the agenda deemed necessary.

- The Committee contributed to the preparation of the 2022 Annual Report and supported the Sustainability Committee and Norm Holding Executive Board.
- The Committee prepared the Norm Holding Board of Directors' Goals document for 2022 and presented it to the Board of Directors.
- The Committee played a role in the preparation of the 2022 Board Efficiency Report and presented this report to the Board of Directors.
- The Committee provided support to Norm Holding Executive Board in the Balanced Scorecard study.

We participated in the TAİDER North Star Family Business Sustainability Program and received the "North Star" grand prize by receiving the highest score at the end of the process conducted by the Executive Board.

We collaborated with Saha Kurumsal Yönetim ve Kredi Derecelendirme Hizmetleri A.Ş. during the Corporate Governance Rating process and completed the process on December 16, 2022, with a score of 9.04.

In 2022, we held 5 committee meetings and informed the Board of Directors about committee activities every quarter.

In 2023 and beyond, we made plans to determine the application and processes for the company's managerial success measurements.

## Remuneration and Nomination Committee

Norm Holding Remuneration and Nomination Committee		
First, Last Name	Position in Committee	Position in Norm Holding
Nedim Uysal	Chair	CEO – Vice Chairperson
Mahmut Öztürk	Member	Executive Committee Member / Industry Group President
Filiz Ergin	Member	Executive Committee Member / Human Resources Director
Caner Melek	Member	Executive Committee Member / Head of Trade Group

\*Current members at the date of publication of the report are listed.

The Remuneration and Nomination Committee is a subcommittee of the Corporate Governance Committee and works in accordance with the company's remuneration policy. On behalf of the Corporate Governance Committee, it convenes at least 2 (two) times a year, in October-December and at times deemed necessary for the efficiency of its activities, and carries out its activities to identify, select and propose managers with senior and managerial responsibilities in Norm Holding companies.

## Early Detection of Risk Committee

Norm Holding Early Detection of Risk Committee		
First, Last Name	Position in Committee	Position in Norm Holding
Erkut Uludağ	Chair	Advisor to the Board of Directors
Muhittin Bilget	Member	Member of the Board of Directors
Mustafa Dođrusoy	Member	Member of the Board of Directors
Tevfik Gani Erpulat	Member	Affiliated Company Board Member
Mahmut Öztürk	Member	Head of Industry Group
Caner Melek	Member	Head of Trade Group

\*Current members at the date of publication of the report are listed.

The Committee convenes at least once every three months. The frequency of meetings can be increased according to the effectiveness of the work and the intensity of the agenda. The Early Detection of Risk Committee monitors the risks of Norm Holding and its companies under four main headings and follows them according to economic/sectoral developments.

The Early Detection of Risk Committee convened three times regarding the activities of 2022. The Corporate Governance Committee submitted its activity report regarding the activities in 2022 to the Norm Holding Board of Directors on March 01, 2023, and it was accepted and resolved by the Board of Directors.

**Sustainability Committee**

Norm Holding Sustainability Committee		
First, Last Name	Position in Committee	Position in Norm Holding
Duygu Uysal Simrooğlu	Chair	Member of the Board of Directors
Nedim Uysal	Member	CEO – Vice Chairperson
Ceyhun Araz	Member	Member of the Board of Directors
Mustafa Doğrusoy	Member	Member of the Board of Directors
Nüket Doruk	Member	Senior Corporate Communications Specialist
Muhsin Doğan	Member	Director of Management Systems and Sustainability
İzel Özgür Tekeli	Member	Sustainability Specialist
Bengisu Ertem	Member	Budget and Strategy Specialist

\*Current members at the date of publication of the report are listed.

It ensures that our employees are informed and internalize our sustainability policy, goals, and practices.

Working Groups plan, implement, monitor, and revise sustainability efforts in line with the goals set by the Committee.

The Sustainability Committee convenes regularly and ensures that sustainability efforts at Norm Holding and its affiliated companies are carried out in an effective and result-oriented manner. Details of the Committee's work are as follows:

- The Committee meets at least once a month. The frequency of meetings can be

increased depending on the effectiveness of the work and the intensity of the agenda.

- The Sustainability Committee sets sustainability targets and ensures the follow-up of these targets by establishing working groups.
- The Committee monitors and evaluates sustainability developments in each business unit of Norm Holding and its affiliated companies.

The Sustainability Committee convened 25 times in relation to 2022 activities. The Sustainability Committee submitted the activity report regarding the activities in 2022 to the Norm Holding Board of Directors on March 01, 2023, and it was accepted and resolved by the Board of Directors.

**Investment Committee**

Norm Holding Investment Committee		
First, Last Name	Position in Committee	Position in Norm Holding
Nedim Uysal	Chair	CEO – Vice Chairperson
Muhittin Bilget	Member	Member of the Board of Directors
Mustafa Doğrusoy	Member	Member of the Board of Directors
Erkut Uludağ	Member	Advisor to the Board of Directors
Kumru Tınaz	Member	Executive Committee Member / Finance and Accounting Director

\*Current members at the date of publication of the report are listed.

It makes recommendations for identifying, defining, prioritizing, monitoring, and reviewing strategic, financial, and operational opportunities that will improve activities by calculating their impact and probability.

The Committee meets regularly, at least once a quarter, and the frequency of meetings may be increased depending on the effectiveness of the work and the intensity of the agenda. It meticulously evaluates the proposals from the Executive Board for all kinds of investments to be made by Norm Holding and its companies.

- The Committee monitors the company's strengths and weaknesses through internal analysis, and opportunities and threats through external analysis.
- The Committee monitors the management of the strategies and projects adopted by the Board of Directors.
- Evaluates significant legal developments and impacts of investments that may affect current operations.

In this context, the Investment Committee convened three times regarding the activities for 2022.



# Risk and Opportunity Management

## Risk and Opportunity Management

As a Norm Holding, we attach great importance to risk management, which is an integral part of a strong management. We closely monitor internal and external risks and opportunities that may affect our company and our sector. Within this framework, the Board of Directors established the Early Detection of Risk Committee to assess and analyze risks, emphasizing the importance of risk management.

While this committee evaluates the risks of Norm Holding and its affiliated companies in general, the Internal Audit Department assigned by the Audit Committee periodically examines and reports on internal risks. In 2022, we launched the Enterprise Risk Management Project, aiming to integrate risk analysis into our business processes. Within the scope of the project, we started risk management studies by selecting pilot companies (Norm Fasteners Nuts, Norm Tooling, STD) and

we continue action planning and follow-up processes.

Within the scope of our sustainability strategy, we identified a total of 25 potential risks and identified those responsible for these risks. Of these risks, 16 were identified as “Critical” based on probability-impact analysis, and we took action to effectively combat these critical risks. Actions were grouped under four main headings, so that the management of risks was handled in a more focused and systematic approach. The Early Detection of Risk Committee, which reports to the Norm Holding Board of Directors, identified nine risks in 2022 and created action plans by assigning them to the relevant functions. Among these risks are “GLOBAL RISKS” that are effective at the global level. These include the energy crisis, recession in Europe and America, the chip crisis in the automotive sector, ongoing logistical risks after the pandemic, and the shift of supply chains from China to the West. At the same

time, “Company Risks” were also taken into consideration and these are the risks arising from the specific circumstances of Norm Holding. Through these efforts, we aim to ensure that our company is prepared for a stronger and more sustainable future by managing risks.

According to the “Global Risks Report for 2023” published by the World Economic Forum (WEF), the top four risks expected to affect the world economy in the next 10 years are environment and climate-oriented.

Failure to mitigate and adapt to climate change, natural disasters, biodiversity loss and environmental degradation represent 5 of the top 10 risks.

We see adverse weather conditions due to global warming as the biggest risk. Therefore, we make various investments against these risks and follow the Global Risks Report every year to assess the risks

that may affect our industry and society.

We conduct risk assessments for environmental, occupational health and safety (OHS) and energy management systems. We set medium-term targets for companies with missing documents and follow up on these targets. At the same time, we aim to minimize our exposure to risks by diversifying supply sources and transportation. We are also working to increase efficiency in production in order to reduce energy demand and procure energy from renewable sources.

All these risk management activities are closely monitored by the Early Detection of Risk Committee and evaluated in detail at quarterly committee meetings. In 2023, we plan to expand risk management efforts to our other companies.

We also plan to join the UNGC’s Business and Human Rights Goal Accelerator program in 2023, through which we aim

to further strengthen our commitments to business and human rights.

## Management of climate-related risks

The “Carbon Border Adjustment Mechanism”, which will enter into force on October 1, 2023, primarily targets the fasteners sector. We closely follow the current legislative changes and aim to support sustainability in our supply chain and reduce carbon emissions by establishing a “Responsible Purchasing Policy”. We are planning to inform our suppliers about reporting their emissions. We take various measures to increase energy efficiency and utilize renewable energy sources in our production processes. At the same time, we aim to minimize risks by ensuring that our suppliers are backed up from different locations in countries affected by climate change. We carry out projects to reduce natural gas consumption and explore the use of alternative energy sources. We regularly share the current status of these

actions at business unit management boards.

We are also advancing investment projects such as solar power plants (SPP) and wind power plants (WPP) to meet our energy needs from sustainable sources. Thanks to these projects, we aim to increase the diversity of our energy sources and use more environmentally friendly energy. In line with our sustainability strategy, we plan to increase our contribution to the environment through energy efficiency and the use of renewable energy and to assume a pioneering role in our sector.

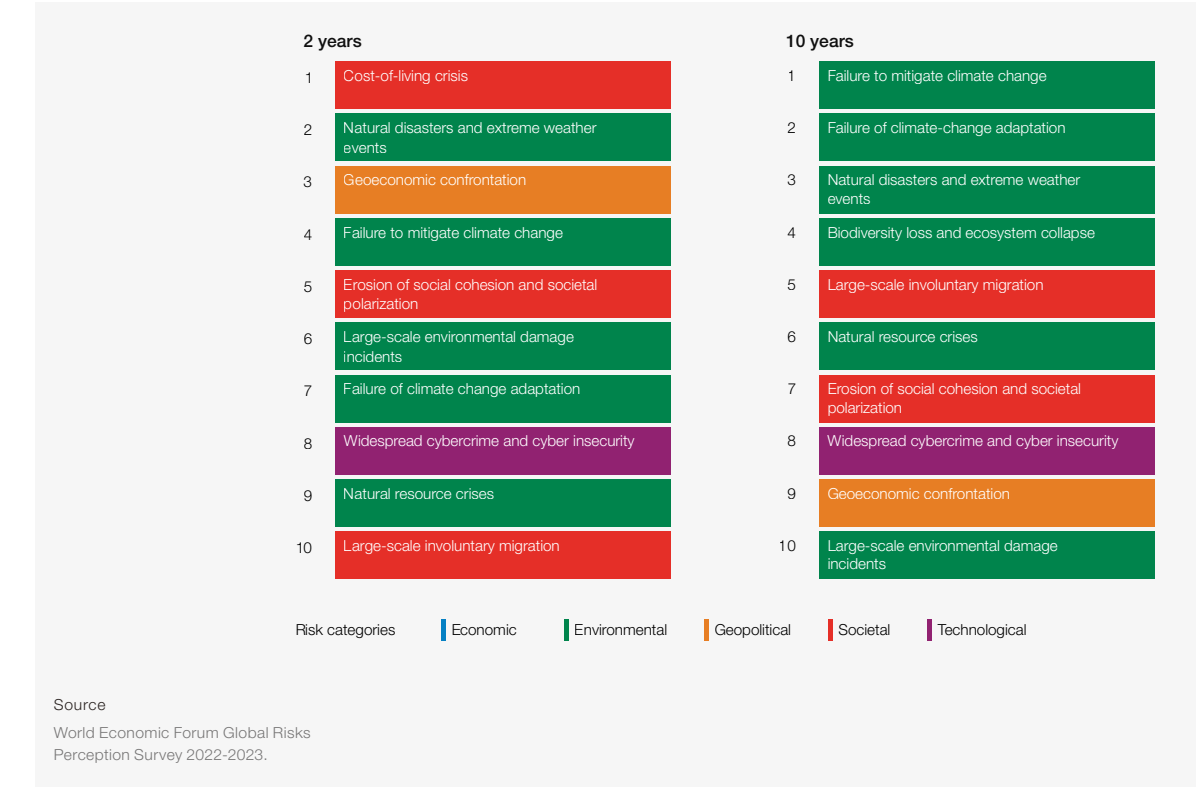

# Ethics and Compliance

Norm Holding Ethics Committee		
First, Last Name	Position in Committee	Position in Norm Holding
Mustafa Doğrusoy	Chair	Member of the Board of Directors
Duygu Uysal Simrooğlu	Vice Chair	Member of Board of Directors – Chair of Sustainability Committee
Mahmut Öztürk	Member	Executive Committee Member / Head of Industry Group
Caner Melek	Member	Executive Committee Member / Head of Trade Group
Kumru Tınaz	Member	Executive Committee Member / Finance and Accounting Director
Filiz Ergin	Member	Executive Committee Member / Human Resources Director
Yıldız Seher Üçer	Secretary	Internal Audit Manager

As Norm Holding, we attach great importance to ethical values and working rules. We express our ethical working rules under four main headings, namely Human Rights, Occupational Health and Safety, Code of Ethical Conduct and Environment in Norm Holding Code of Ethics, which is accessible to all our stakeholders on our website. We adopt the principles of

compliance with legal regulations, respect for personal rights, equality, honesty, environmental awareness, and fair competition.

We established an independent hotline and Ethics Committee for our employees and business partners. Our Ethics Committee is responsible for ensuring that employees

act in accordance with ethical rules and investigating violations.

Under the Ethical Code of Conduct Operations Policy, we have organized our Ethics Committee to deal with and evaluate unethical situations. Our Ethics Committee is managed by an independent service provider and plays a completely independent role within the corporate structure.



Norm Holding Ethics Committee takes responsibility for the process of reporting and evaluating ethical violations. Employees and business partners can report ethical violations by using the report and referral hotline (444 3845) or e-mail address

(normholding@etikhat.com.tr). These channels have been carefully designed for privacy and security and provide commitments on the confidentiality and processing of breach notifications.

In 2022, all notifications received were reviewed by Internal Audit or the senior manager of the relevant function/business unit and submitted to the Ethics Committee. **During 2022, a total of 17 reports were made to our Ethics Hotline and all reports were successfully resolved.**

We care about the internalization of ethical culture in our companies. For this reason, a **total of 695 hours of ethics training** was provided to our companies within our holding.

## Anti-Bribery and Anti-Corruption Management

With a “zero tolerance” approach, we take a firm stance against corruption and bribery

in our corporate culture, and we implement strict regulations and policies in the sector we operate in and in the way we do business.

Our commitment to fighting bribery and corruption is further reinforced through our Anti-Bribery and Anti-Corruption Policy. This policy clearly states that the company is committed to the principles of compliance with relevant anti-bribery laws. In order to protect our reputation and integrity, we carry out our activities in the light of this policy, which serves as a guide for identifying and preventing possible bribery and corruption activities.

We have an independent hotline that our employees and business partners can reach in case of any bribery or corruption, and this is supported by our Ethics Committee. Our hotline is managed by an independent service provider and its working principles are clearly stated in Norm Holding Code of

Ethics Operations Policy.

Through our Anti-Bribery and Anti-Corruption Policy, we are committed to full compliance with relevant laws and aim to identify and prevent potential bribery and corruption activities. In addition to protecting the reputation and integrity of our company, this policy encourages our employees and business partners to behave in accordance with ethical values.

In line with our business principles, we take serious action when any corruption or bribery is detected. Disciplinary and judicial proceedings are initiated when necessary. In our company, official figures are not altered in any way and in case of any discrepancies in the analysis and records, the internal audit team and the Ethics Committee are immediately informed.

As stated in Norm Holding's Disciplinary

Regulation, abuse of employer's trust, theft and similar behaviors are among the grounds for termination. This regulation is among the internal documents of Norm Holding. Furthermore, in the Ethical Code of Conduct Operations Policy, issues such as bribery, theft, use of company resources for personal gain are classified as misconduct. During the reporting period, there were no confirmed public cases related to corruption.

Norm Holding Anti-Bribery and Anti-Corruption Policy is available here.

## Human Rights

Our Holding adopts a corporate culture that sees differences as richness and aims to respect human rights. Norm Holding Code of Conduct is an important guide that determines employee relations and the company's attitude towards employees.

With the priority of protecting the rights

of employees and creating a safe working environment, we do not accept ethical violations such as forced labor, child labor, human trafficking, harassment, defamation, discrimination, corruption, bribery, blackmail, abuse, and conflict of interest. In competitive situations, we make it a principle to act in a way that does not affect market conditions and we believe that ethical principles support sustainable growth by increasing the profitability of companies.

As a member of the UN Global Compact, we are committed to acting in accordance with our ethical principles and creating a safe working environment by protecting the rights of our employees.

As Norm Holding, we will prepare our Human Rights Policy in 2023 and share it with all our stakeholders.

# Message from the Head of Industry Group

Esteemed Stakeholders,

We are pleased to share with you our new report, which includes the progress in our sustainability journey and our sustainability data for 2022.

In the reporting period, we faced different crises in global scenarios as we moved towards normalization after the effects of the pandemic. While the effects of the pandemic on the global economy continued in the first quarter of the year, tensions between Russia-Ukraine, the US-China, Turkey-Greece, and China-Taiwan also had a negative impact on the economy. As inflation hit multi-decade highs across the globe, tightening financial conditions, energy supply disruptions and declining purchasing power of individuals led to an economic slowdown in many countries, particularly in Europe.

As Norm Holding, we continued to grow

in 2022. The share of exports in our total sales increased from 46% to 51%. As part of our external investments, construction of our US production facility continues apace and we are targeting the end of 2024 to start production. In addition, we started to produce fasteners in larger diameters and sizes in the field of hot forging with Norm Forging company and we plan to grow in the field of export.

We are also taking important steps in the field of Occupational Health and Safety (OHS). We aim for a 15% reduction in occupational accidents in order to achieve the “zero occupational accidents” target, and in this direction, we organize the necessary training sessions and use automation, artificial intelligence and IOT technologies in processes.

As the Industry Group, we set our targets and took our action plans accordingly. We would like to thank our customers,

business partners, stakeholders and all our colleagues who supported us in this process. Thanks to your valuable contributions and cooperation, we have taken important steps to achieve our sustainability goals and will continue to move forward with determination.

Best regards,

Mahmut ÖZTÜRK  
Head of Industry Group



# Industry Group

## Norm Fasteners Bolts- Screws

**96% compliance with 2022 targets**

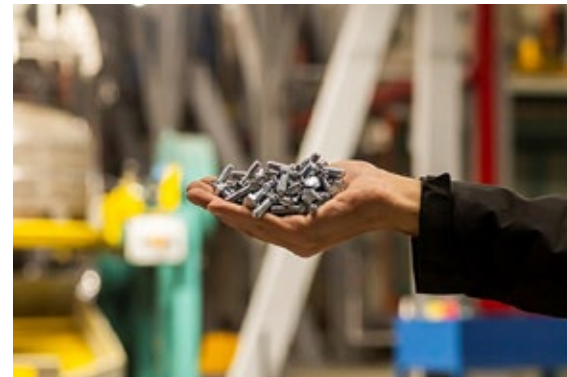

In 1973, the company started bolt production in Bornova, Izmir, and built a modern facility in Izmir Atatürk Organized Industrial Zone in 1994. Norm Fasteners Bolts which has the highest production capacity within Norm Holding, covers three different production facilities, two bolt and one screw production facilities.

Norm Fasteners Bolts Izmir and Salihli

and Screw production facilities mainly supply standard and special fasteners to the automotive main industry and supplier industry.

The production infrastructure was strengthened with a production capacity of 200,000 tons, 400 forging machines and 21 heat treatment lines. Globally, it continues its activities with 18 production centers, 13 logistics and sales centers operating in 9 countries. It is actively doing business in countries such as Canada, the USA, the United Kingdom, Germany, France, Poland, Romania, Turkey, and China and continues its strategy of stepping into new markets. In 2022, it prioritized growth with a new sales center in Canada.

Norm Fasteners achieved 96% compliance with its targets in 2022 and realized 110 thousand tons of production. It increased exports from 43% to 51%. Bolt and screw production increased by 4% and the

share of exports in total sales tonnage increased by 7% compared to the previous year. It achieved 92% success in customer satisfaction surveys. It continued to invest in machinery, increased its capacity and continued to grow. Izmir and Salihli plants have a total production capacity of over 50,000 tons. With a target of 20% growth in 2023, the Company continues to make uninterrupted investments.

## Norm Fasteners Nuts

**Leading Manufacturer of Turkey**

Norm Fasteners Nuts is a solution partner of major manufacturers and strong brands in the automotive, white goods, electronics, furniture, construction, and machinery sectors in Turkey and abroad. It is Turkey's leading manufacturer of various products such as special welding nuts and bushings, which are used, especially in the automotive industry.



In 2022, it increased its annual production capacity at its Izmir production facility to over 50 thousand tons. In the same year, it successfully completed the investments it had planned. Layout adjustments and modernization work at the Izmir Nuts plant are still ongoing and will continue to be invested in going forward.

Norm Fasteners Nuts, continues to be a preferred brand in different sectors and countries by standing by the customer with the motto "global scale, individual attention" and increasing its service level day by day.

In order to reflect the great importance

it attaches to digital transformation, it implemented the "Paperless Factory Project" and completely digitalized its production forms. Production tracking,

**With the "Paperless Factory Project", production forms are completely digital**

maintenance forms and other processes are now carried out on digital platforms, meeting customer needs digitally. It meets approximately 17% of the energy consumption of its production facilities through SPP projects and reduces the amount of chemical waste through environmentally friendly practices. With a sustainable and environmentalist approach, it is moving forward with a commitment to leave a clean world for future generations.



## Norm Fasteners America

**4 important projects are completed**

The primary goals of Norm Fasteners America, which was established in 2018, are to improve customer satisfaction, expand its customer portfolio, and bring new customers.

Norm Fasteners America delivered a successful performance in 2022 with a nearly two-fold growth in turnover. It

completed 4 important projects focused on digitalisation. These projects included warehouse digitalization and RPA (Robotic Process Automation) projects, which increased the control of customer orders and the efficiency of logistics processes. It aims to increase turnover by pursuing a strategy of winning new customers to increase its market share among electric vehicle manufacturers. Due to increasing sales and warehouse utilization rate, the company plans to invest in a new warehouse in 2023 and to start the first bolt production in a new 33 thousand square meter factory area by the end of 2024.

## Norm Fasteners Germany

**50% increase in turnover**

Norm Fasteners Germany was established on December 4, 2012, in the center of Spaichingen, Germany. The main field of activity of the company is to supply, store,

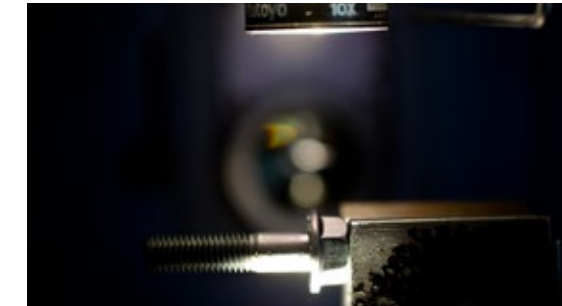

and sale of fasteners to the automotive main and sub-industry.

Norm Fasteners Germany made significant progress in 2022. The 50 percent increase in turnover reflects its successful growth performance. It increased its export ratio from 13% to 38% and achieved a strong position in international markets. Successfully completed SAP phase 1 transition and achieved SAP integration with automotive supply industry companies. With the RPA projects realized in cooperation with Normie, it increased operational efficiency and succeeded in transferring transactions on the customer portal and manual orders to the SAP

# Industry Group

## “A” performance score from all customers

system. Increased warehouse capacity by 41 percent by making warehouse workflows more efficient. A performance score of A from all customers indicates an outstanding achievement in customer satisfaction. In 2023, it plans to increase its turnover by focusing on new customers and projects, moving forward with growth targets.

### Norm Tooling



Norm Tooling, established in 2003, started mold production for Fasteners and machining special parts manufacturing activities in 2006. Norm Tooling aims to provide the best service with high quality, economical price, and a Just- In-Time (JIT) management strategy. Norm Tooling, which specializes in machining

## 70% of the budget goes to machinery investments

and cold forging tooling, operates with 250 experienced staff and modern production

technologies. It has an annual capacity of 60,000 diamond molds and 350,000 steel molds.

Norm Tooling focuses its R&D activities on following and integrating innovations to support sustainable production. It puts targets such as reducing waste in the production process, improving mold performance, developing competitive products and localization at the center of its R&D activities.

In 2022, Norm Tooling performed successfully with a growth of 30 percent, strengthened its position in the industry and expanded its customer portfolio. With its new 5,000 square meter production facility, it expanded its factory area to a total of 10,000 square meters. In the production facilities, mold manufacturing and machining areas operate in two separate factories. It has completed three strategic projects and is successfully

pursuing other projects. Digitalization and operational excellence were prioritized and investments were made. It updated its technological infrastructure by allocating 70% of the budget to machinery investments. It made its production processes more efficient with steps such as the investment in a heat and coating facility and the improvement of the technological infrastructure of the machines. In 2023, it will continue its efforts to consolidate its leadership in the sector.

## Quality control machines that ensure 100% product control

### NRM Engineering

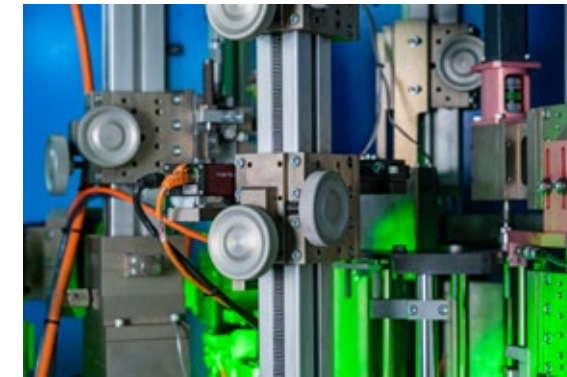

Established in 2014, NRM Engineering operates in the fastener industry and develops quality control machines that provide 100% product control. It also works in the field of “special machine design and manufacturing”. NRM Engineering focuses on the fastener industry.

In 2022, NRM Engineering achieved significant success. In the fasteners sector, it carried out priority studies to expand and develop the production range of 100% product control machines, to strengthen and standardize the product infrastructure.

In 2023, it aims to expand in overseas markets, with a particular focus on the European market. It plans to diversify by directing 70% of total sales to companies other than Norm Holding. It plans to continue its loom investments and invest in an erosion machine in the future. The quality control department is now operational with its equipment, aiming to make the processes more effective and efficient. It aims to be among the top 5 companies in the European market.

### Norm Forging



Norm Forging was established in Salihli

district of Manisa in 2021. Our company, which operates in Manisa/Salihli Organized Industrial Zone in a closed area of 4500 square meters, continues its activities in different sectors such as construction, agriculture, railway, energy, defense, and machinery industry, especially in the automotive sector. With an investment approach that closely follows the current technology in the hot forging industry, Norm Forging aims to reach a strong position in the sector.

# Head of Trade Group's Message

Dear Business Partners and Stakeholders,

While 2022 saw a recovery for the global economy, the effects of the Covid-19 pandemic were still deeply felt. During this period, Norm Holding Trade Group struggled with challenges such as macroeconomic fluctuations, geopolitical and diplomatic risks. We achieved our goals by maintaining our determination and business discipline.

We strive for a sustainable future with the 2030 Sustainability Strategy we have set in line with the United Nations Sustainable Development Goals. We focus on ensuring that our products and services make a positive contribution to the environment and society.

By achieving large increases in our turnover and exports, we increased our turnover by 25% in 2022 compared to the previous year and increased our exports by 77%.

As STD, we exported to 38 countries from our Turkey warehouses and 22 countries from our ST Trading warehouse in 2022. In our Norm Fasteners Romania company, in addition to our automotive customers, we have increased our product range for different sectors. With a strong capacity of 45,000 pallets and a product range of nearly 25,000 products, we increase availability and continue to offer customers a wide range of services with our strong capacity and product range.

In order to increase our product diversity, we started to offer new products such as power tools, welding machines, hardware, and machining parts by using the competence we gained from fasteners in other areas. We managed to rank among the top 3 dealers of Stanley Black & Decker branded power tools and expanded our collaborations with other brands.

Showing our success in fasteners in the

hardware group, we signed a distributorship agreement with "Awelco" in Turkey. Thanks to our effective marketing strategies and wide product range, we managed to maintain our profitability in 2022.

We were the 585th company to receive the "Authorized Economic Operator Certificate", an international status, and the 44th company to receive the "Export On-Site Customs Clearance". By actively using technology, we incorporated data analytics into our processes and started to use CRM systems effectively in customer management.

As Norm Holding Trade Group, we have achieved success not only in our business but also in our efforts focused on sustainable growth and customer satisfaction. Our customer satisfaction rate is 99% and we recognize the importance of this result and strive to further strengthen our customer focus.



Best regards,

Caner MELEK  
Ticaret Grubu Başkanı



AHAL/TÜRKMENİSTAN  
ALEXANDRIA  
ATHINA  
ATTIKI  
BAKU  
BASSANO DEL GRAPPA  
BATUM  
BILBAO  
BOLOGNA  
BOSNA HERSEK  
BRATISLAVA  
BRNO  
BUENOS AIRES  
CASABLANCA  
CAYENNE  
DE DONT COUVERTE AVIGNON  
DNIPROPETROVSK  
DUBAI

DULOVA/SİLİSTRA  
ERBİL  
GALATI  
GAUTENG  
GAZİMAGOSA  
GERMANY  
GİRNE-KKTC  
GOSTIVAR  
GOTHA  
HARKOV  
HAYFA  
HONG KONG  
Jönköping Län  
KHARKOV  
KILKIS  
KOBULETI  
KRALOVEHRADECKÝ BÖL  
KUZEY REN VESTFALYA

LA SOUKRA-TUNİSIA  
LARİSSA  
LEFKOSA  
LETONYA  
LVIV  
MAIA  
MILANO  
MINSK  
MODENA  
MONZA E BRIANZA  
MOSKOVA  
MURES  
NIJNI NOVGOROD  
NIS/SERBIA  
NOVI BEOGRAD  
ODESSA  
ONTARIO

PADOVA  
PIESTANY/SLOVAKIA  
PIRAEUS  
PLOVDIV  
PREVEZA  
PRISTINA  
QAZAX  
R.SRBİJA  
REGGIO EMILIA  
RUSE  
SAFAT  
SAKIET EZZIT  
SAMARKAND  
SERBIA  
SFAX-TUNİSIA  
SKOPJE  
SREBRENİK  
SWADZIM-POZNAN

SYDDANMARK  
TBİLİSİ  
TEL AVİV  
TETOVO-MACEDONIA  
THESSALONIKI  
TIRANE  
TUNİS  
VAS  
WEST MIDLANDS-UNITED  
KINGDOM  
YAVNE  
YVELINES  
ZAGREB  
ZARAGOZA  
ZEPCE  
ZUID-HOLLAND

- A warehouse with a capacity of 17,500 pallets in İzmir
- A warehouse with a capacity of 7,200 pallets in Kocaeli-Dilovası
- A warehouse with a capacity of 9,300 pallets in Ankara-Kahramankazan
- A warehouse with a capacity of 2,500 pallets in Manisa Salihli
- It exports to approximately 50 countries from 66 cities with 17 marketing and sales representatives in related warehouses.



7

LOGISTICS CENTER  
(Poland, Romania, Türkiye)



87

EXPORT POINT

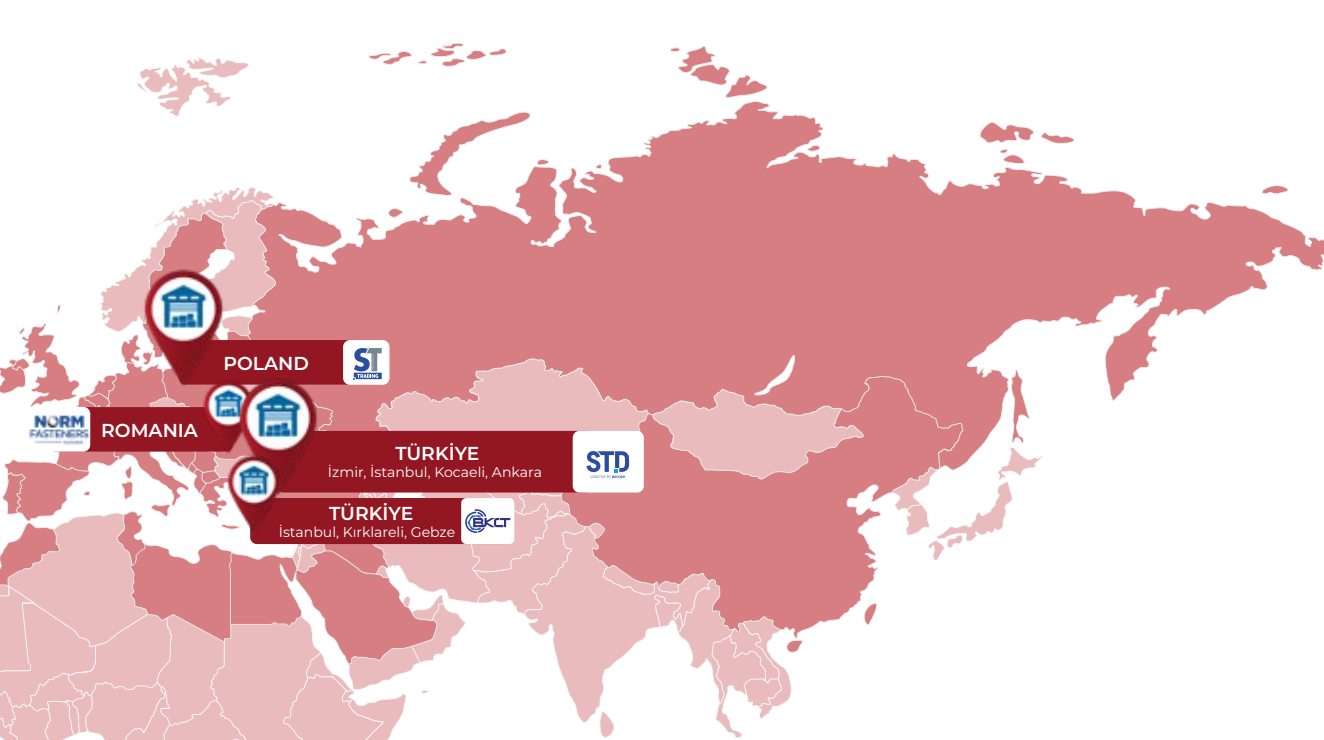

# Trade Group

## Standart Civata (STD)



Established in 1982 within Norm Holding, STD has taken its place in the top ranks in the sector since its establishment; it pioneered technological advancements through the innovations and became the leading company of the sector. Operating in 67 different cities across Turkey and in more than 50 countries in Europe, STD operates in Izmir Atatürk Organized Industrial Zone in a closed area of 10,000 m<sup>2</sup>, totaling 20,000 m<sup>2</sup>; in Dilovası in a closed area of 3,000 m<sup>2</sup>, totaling 5,000 m<sup>2</sup>; and in Ankara in a closed area of 3,500 m<sup>2</sup>, totaling 5,600 m<sup>2</sup>.

In 2022, a year marked by global and local crises, STD managed to achieve its targets

and increased its sales by 25% compared to the previous year. Continuing to grow with exports to 22 countries through ST Trading Poland, which was established in line with the strategy of expanding its distribution network, and to 38 countries from its warehouses in Turkey, STD's total exports increased by 77% compared to 2021 and reached EUR 32 million. With its capacity reaching 45,000 pallets and its product range and distribution network expanding every year, STD reinforces its sector leadership as the company that responds to customer demands in the fastest and most accurate way.

STD, which continues its activities with the aim of continuing its sectoral expansion by increasing its product range, served sectors such as energy, construction, agriculture, furniture, electricity, occupational safety, defense, transportation, automotive, white goods, machinery, and mining with nearly 25,000 different product types in 2022. While fasteners constitute STD's main sales

group, these groups include power tools, plaster nets, fly nets, drawer slides, hinges, gas pistons, door hydraulics, locks, gloves, tapes, bit tips, meters, hair wicks, which have achieved high sales momentum in the last 5 years. In 2022, new products added to the product range were welding machines, inflatable wheels, push-pulls, and pallet trucks.

Continuing its successful sales performance year after year, STD became one of the top 3 dealers in Turkey in 2022 for Stanley Black & Decker branded power tools, which it started selling in 2019. Reflecting the product diversification competence gained from fasteners to the hardware group, STD has added a new one to its global brand network by agreeing with the Italian company Awelco for the Turkish distributorship of welding machines. STD maintained its profitability in 2022 thanks to its experienced sales team, effective marketing strategies and wide product range.

In 2022, the sales of parts produced by machining, sheet metal processing, additive manufacturing and hot forging methods produced in the facilities affiliated to Norm Holding started.

In 2022, STD became the 585th company to receive YYS (Authorized Economic Operator Certificate) and the 44th company to receive Export On-Site Customs Clearance in Turkey.

The survey conducted by the independent research organization ERA Research Consultancy to evaluate STD's services in 2022 successfully resulted in a "Domestic Customer Satisfaction Rate" of 99%.

Supporting its strategic goals with its digital infrastructure, STD aims to make the B2B portal it uses in domestic sales available as Global B2B by mid-2023, enabling stock visibility of all its customers' domestic and international warehouses and tracking of their related accounts.

## ST Trading



ST Trading is a marketing subsidiary under the trading group of Norm Holding. Established in Poznan, Poland, our company has a closed warehouse area of 2.500 m<sup>2</sup>. ST Trading, which exports to 22 countries, especially Italy, Greece, and Austria, had a successful year in 2022 by increasing its turnover by approximately 50% compared to the previous year, taking advantage of the advantages of its geographical location.

ST Trading completed ISO 9001 and ISO 14001 certifications in 2022. It realized new racking investments and increased its warehouse capacity from 2,318 pallets to

4,500 pallets. In 2023, ST Trading will make its online sales platform, which it has been using since 2020, available to its customers in the European market. In order to increase its ability to respond to customer demands, ST Trading aims to increase its product range from 2,500 to 10,000 by deepening in the pvc, solar energy panels, agriculture, and automotive sectors.

### Norm Fasteners Romania

Founded in 2019 in Ilfov, Romania, Norm Fasteners Romania started its activities in 2020 with a capacity of 5,000 pallets in its 2,450 m<sup>2</sup> logistics center.

Norm Fasteners Romania aims to provide on-site service with high quality products to its customers in various sectors such as automotive, construction, energy, furniture, white goods, machinery, and agriculture.

Norm Fasteners Romania managed to increase its turnover by 90% compared to the previous year. In the area of

environmental sustainability, waste management procedures, recycling system and waste reduction were implemented with Financiar Reciclyng. In the area of managerial sustainability, Geoffan provided consultancy services to the Ministry of Environment for waste management system operations, environmental reporting, and environmental impact procedures in accordance with Romanian law. We worked with Finexpert on accounting compliance, labor law compliance and wage compliance. Exclusive Work Ethics has also worked on occupational safety regulations, regular occupational safety training sessions and mandatory reporting for the Ministry of Labor.

Norm Fasteners Romania plans to commission its B2B platform creation efforts in the field of digitalization, which started in 2022, in 2023. Continuing its efforts to increase its market share, Norm Fasteners Romania aims to grow a competitive sales policy by expanding its product range in

this context.

### Mubiko

#### "Click and it comes!"

Mubiko.com is an e-commerce site established in 2021 within Norm Holding. It reflects Norm Holding's service understanding that does not compromise on quality and vision, which is among the 500 largest industrial organizations in Turkey. It has a wide range of products including Clothing, Shoes, Bags, Accessories and Home Decoration categories. Headquartered in Izmir Atatürk Organized Industrial Zone, Mubiko.com has adopted an innovative service policy that attaches importance to customer satisfaction. It stands out with its strong logistics network and fast delivery strategy.

# Other Areas of Activity

## Norm Digital



### Norm Digital, More Digital!

Founded in 2021 within Norm Holding, Norm Digital operates in Izmir Dokuz Eylül University Technopark DEPARC by adopting a continuous improvement culture. Norm Digital, which offers digital transformation consultancy to businesses with more than 200 employees, provides services in many areas such as robotic process automation (RPA), SAP Application Consultancy, System and Network Consultancy, Cloud Services, Security Services, IoT with its expert team.

In 2022, Norm Digital expanded the services it provides to Norm Holding and its affiliated companies to non-group customers, increased its number of employees more than 4 times and made a rapid entry into the sector with 26 customers and 7 business partners in 15 different sectors.

Norm Digital continues its expansion strategy in Turkey centered on the Aegean Region. With the vision of becoming a global company, market and sector research continues in Germany, Poland, Romania, and the USA.

In the field of software, the automotive sector has been prioritized in order to include artificial intelligence-supported solutions in the product and service range. Efforts are underway for sectoral expansion.

In the field of SAP Consulting, it is planned

to provide services in Private Cloud ERP transformation support and applications to medium and large-scale manufacturing companies in the production, technology, and energy sectors, especially in the automotive and FMCG sectors. For small-scale companies, Public Cloud ERP transformation and consultancy services and SAP CX Commerce Cloud services for the B2B needs of businesses are in progress.

### One of the top 10 companies using RPA in Turkey

In the field of Data Analytics & RPA, it is aimed to expand the sector and customer network, especially with finance, insurance, and banking customers. With the experience in production companies, we continue to work to provide services in the field of E-Commerce.



Normie offers businesses the opportunity to get rid of repetitive tasks and focus on more creative work, while Recruitment Platform Vinter aims to save time and costs by creating an effective and transparent recruitment process between candidates and human resources departments.

Norm Digital also aims to contribute to the processing of data in a more agile way by digitalizing the field management of enterprises with Ocea'N, the Production Management System. Likewise, Low Code

Platform Kuika enables even individuals with no software knowledge to develop their own solutions through a graphical user interface.

Norm Digital also has an important position as one of the first 10 companies using RPA in Turkey.

## Norm Additive

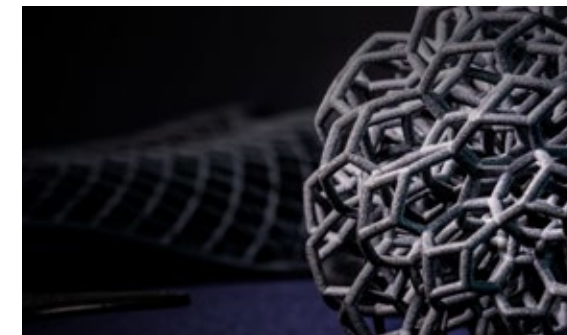

As Norm Holding, in accordance with the principle of "Our forward-looking steps are always in pursuit of perfection", Norm Additive was established in 2021 with the vision of carrying its advanced

manufacturing capability to the field of additive manufacturing. Norm Additive, which officially started its activities in October 2021, realized the planning of its 700 m2 facility by creating a twin model in the computer environment. This model helped to accurately design the factory layout by including all production steps.

### Factory layout design in computer environment

Norm Additive's products are shaped according to customer demands and requests and cover a wide range from end products to prototypes. Norm Additive produces solutions to customer demands with advanced additive manufacturing methods in both metal and plastic parts.

The main objective of the company is to design and manufacture products in the

high-tech industry class with domestic resources and manpower without being dependent on foreign sources. By taking an early step into the field of additive manufacturing, which is seen as the production technology of the future, the main goal is to gain technical expertise in this manufacturing method and to have a say in the market.

Norm Additive reached the result by working on four different software and calculation algorithms within the scope of digitalization in 2022. In the first software, detailed cost calculations for metal PBF, polymer FDM and MJF processes can be made. The second software is material selective. Many OEMs and manufacturers use many different materials in their products and parts. A decision-making algorithm running in the background selects the most suitable alternative manufacturable material according to the mechanical and thermal variables required

by the customer. The third software is the software that calculates the energy performance variables to be used in additive manufacturing design processes and decides on the best energy consumption. Our last software is the production risk determinant. In additive manufacturing systems, the many geometric variables of the designed part and the placement of this part in the machine production table are critical for production success.

One of the most important advantages of additive manufacturing is that the amount of waste is very low. Dust particle collection filters were installed at the end of the ventilation systems installed in the production area to collect dust that may be emitted from the polymer machine and dust that may be emitted from the sandblasting lines. These filters are replaced depending on production capacity. In 2022, no filter waste was generated.

# Other Areas of Activity

## Norm Coating



Founded in 1998 to provide services in the field of coating in the fastener sector, Norm Coating has a leading position in the sector with a total of 5 factories in Izmir, Salihli and Sakarya. In addition to having zinc, zinc-nickel, phosphate, and lamellar coating facilities licensed by MacDermid, Dörken MKS, Magni and NOF (Geomet), the company adopts new generation production technologies with the sorting and packaging facilities it acquired in 2020. Norm Coating's priority is to provide customers with the highest level of quality service, reflecting sustainability, human

and environment-oriented approach.

Norm Coating, which sets human, environment, and sustainable growth principles as its target, continues its activities in line with its strategic priorities and targets.

Established in 2021, the Environment department established and certified the ISO 45001 Occupational Health and Safety Management System, ISO 14001 Environmental Management System, and ISO 50001 Energy Management System as part of its sustainability efforts.

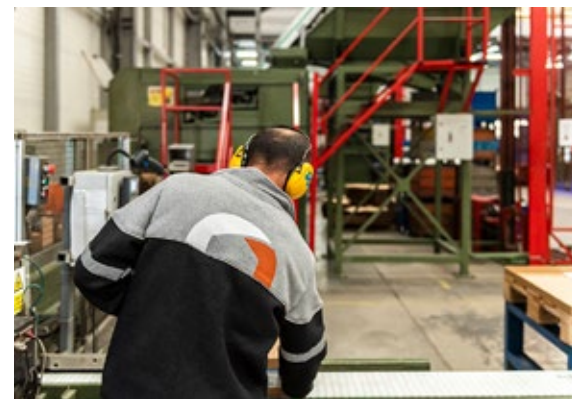

In 2022, 1,000,000 kW/year of solar energy was generated at the Salihli plant, and the plant's heating system was renewed and the waste heat from the furnaces was used to heat the factory's interior.

In the "OSB Stars Survey" conducted by the Organized Industrial Zones Supreme Organization in 2022, the Company ranked 2nd in the category of "Company with the highest increase in female employment" and 9th in the category of "Company with the highest increase in employment".

Norm Coating established Norm Coating Academy in 2022 in order to transfer its knowledge and experience in coating technologies to all its stakeholders. It is aimed to contribute to the development of the sector with the information sharing provided by the academy where theoretical and practical training sessions will be provided.

## Nordes Food

Founded in August 2022, Nordes aims to offer strawberries, cherries, sour cherries, plums, grapes, tangerines, grapefruits and oranges in compote form and asparagus vegetable in cans and glass jars to all European, especially EU, Japan, Australia, South Korea, and the US markets.

The company, where female employees will predominantly work, will employ up to 460-500 people, although this may change periodically.

Nordes' production site is planned to be completed in the first quarter of 2023 and start production in the third quarter of 2023.

The trademark registration of NORDES GIDA SANAYİ VE TİCARET ANONİM ŞİRKETİ (NORDES GIDA INDUSTRY AND TRADE ANONİM ŞİRKETİ) has been approved and protected by the Turkish Patent and Trademark Office.

# Awards and Achievements

## 3 Big Awards to Norm Holding from Stars of Export Award Ceremony

At the "Stars of Export" Award Ceremony organized by the Aegean Exporters' Associations, as Norm Holding, we won 2 major awards with our Norm Fasteners Bolts and STD companies. At the same ceremony, our Honorary Chairperson of the Board of Directors Nedim Uysal was also honored with the "Doyen of the Sector" award. Norm Fasteners Bolts received the gold award in the "Other Iron and Steel Products Export Champion" category and was also awarded in the gold category within the scope of the Aegean Ferrous and Non-Ferrous Metals Exporters Association. Our Standard Bolts company won the award in the bronze category.



## "Best R&D Project of the Year Award" from İZTEK to Norm Holding

Norm Fasteners R&D Center won the "Best R&D Project of the Year" award at the İZTEK Innovation R&D and Technology Awards 2022 event with its "Artificial Intelligence Supported Mobile Application Determining Fastener Dimensions and Standard" project developed with Kalybe.AI.



## Norm Holding and our affiliated companies received 12 awards in 2022.

## "TAIDER North Star Sustainability Award to Norm Holding"

With our successful efforts in the field of sustainability, we were awarded at the TAİDER 5th North Star Award Ceremony. We received the North Star award for our impressive work in the categories of "Corporate Governance", "Society", "Employees" and "Environment".



## Another Award for Normie!

Our digital teammate Normie's website normie.ai received an Honorable Mention at the Awards. Explore our award-winning website and meet Normie. Congratulations Normie!



# Awards and Achievements

## Award to Norm Coating and Norm Fasteners Companies from OSBÜK

According to the results of the "OIZ Stars Survey" organized by the Organized Industrial Zones Supreme Organization (OSBÜK);

- Norm Coating ranked 2nd in the category of "Company with the highest increase in female employment",
- Norm Coating ranked 9th in the category of "Company with the highest increase in employment" and Norm Fasteners ranked 10th.

We are very happy and proud to support women's participation in business life.



## "Norm Holding Ranked Second in RDCONF R&D and Innovation Awards"

In the "2022 RDCONF R&D and Innovation Awards" organized with the support of ARGEMİP, we were awarded the second prize in the "Steel Structure and Production" sector with our study titled "Realization of Mechanical Strength and Torqueing Studies for Weight Reduction in Norm One Way Patented Product".



## The Best of Izmir "Education Volunteer of the Year" award

Our Honorary President Nedim Uysal was awarded the "Education Volunteer of the Year" award at the "Izmir's the Best Award Ceremony" organized by Karşıyaka Life Magazine. We continue to support education and contribute to our youth.



## Grand Award for the "ENLider Sensin" Program

With the "ENLider Sensin" Leadership Development Program, we won the silver award in the "Best Leadership Development Programs" category at the 2022 Human Resources Excellence Awards organized by the Brandon Hall Group.



## We attended the General Assembly of the Association of Global Compact Signatories

In 2023, UN Global Compact Turkey was established as the "Association of Global Compact Signatories". The first Ordinary General Assembly of the Association was held in The Marmara Taksim on June 8, 2023, with the participation of its signatories and stakeholders. Board Member Mustafa Doğrusoy attended the association meeting on behalf of Norm Holding.



## Developments After the Activity Period

### Our Corporate Rating Score was determined as 9.04

Our Corporate Governance Rating Score was determined as 9.04 out of 10 by Saha Kurumsal Yönetim ve Kredi Derecelendirme Hizmetleri A.Ş., which determines the corporate governance rating of companies with the license of the Capital Markets Board (CMB), as a result of the analysis covering Norm Holding and all our affiliated companies.

With this report, our Board of Directors was ranked in the "Best Practice" category in terms of structure and functioning;

- We are honored to certify that we have complied with the CMB Corporate Governance Principles and implemented all policies and measures in this context,
- We operate our management and internal control mechanisms effectively,
- We identify and manage all corporate governance risks,
- We perform our public disclosure and transparency activities at the highest level.

We would like to thank all our colleagues who contributed greatly to this success.



## Silver Award from EcoVadis to Norm Fasteners

In the 2022 results of EcoVadis, which analyzes the sustainability performance of more than 50,000 companies based on documented evidence and ranks all companies as a result, Norm Fasteners was awarded a silver medal by ranking in the top 25% of all companies evaluated. Norm Holding aims to continue its successful efforts in the field of sustainability with the investments it has made and the business processes it has developed in the coming period.



## Deloitte "En İyi Yönetilen Şirketler" Ödülü

Deloitte Private tarafından 45 ülkede uygulanan şirketlerin strateji, yetkinlik ve inovasyon, kültür ve adanmışlık, yönetim ve finansallar olmak üzere dört ana başlıkta incelendiği 'En İyi Yönetilen Şirketler' programı 2022 yılı Türkiye kazananları açıklanmıştır. Tüm şirketlerinin ve paydaşlarının benimsediği ortak gelecek vizyonuyla, sürdürülebilir geleceğin inşası için çalışan Norm Holding, Türkiye'nin En İyi Yönetilen Şirketleri arasında yerini almıştır.



# Webinars and Panels attended

## We attended the 10th Ordinary General Assembly of UN Global Compact Turkey

As part of our support for the work of UN Global Compact Turkey, we attended the 10th Ordinary General Assembly of Global Compact Turkey, which was organized for the organizations from Turkey that joined the UN Global Compact. On March 25, 2022, at the ceremony held at the Intercontinental Hotel, Duygu Uysal Simrooğlu, Member of the Board of Directors and Chair of the Sustainability Committee, signed on behalf of our company.



## We Talked About Our Sustainability Projects at HR Communicators Event



Duygu Simrooğlu, our Board Member and Sustainability Committee Chair, shared valuable information about sustainability, by talking about our sustainability projects that value the future.

Stating that our work in the field of sustainability continues, Duygu Uysal Simrooğlu started her speech with Norm Holding's story of meeting sustainability and touched upon 11 important issues that

we prioritize in this regard and our related projects.

Duygu Uysal Simrooğlu touched upon the new work we will carry out in this field, our established subsidiaries and customer relations, and also talked about how she included the Norm Holding team, whose training we attach great importance to, in the process.

Duygu Uysal Simrooğlu, who shared the importance of being a member of a family business in the sustainability journey, ended her speech with a beautiful message. "The world does not need humans to survive, but humans need the earth to survive. That's why we care about the environment because of people."

## We Participated in UN Global Compact Climate Goal Acceleration Program

In order to determine science-based emission targets and create an effective road map in the process of carbon neutrality, UN Global

We participated in the Climate Ambition Accelerator carried out under the leadership of Compact.



The Climate Target Acceleration Program, a 6-month program, supports companies in setting emission reduction targets in line with the Science-Based Targets Initiative (SBTi) methodology. At the same time, the program contributes to companies having the necessary knowledge and skills for the "1.5°C target", which means preventing many permanent effects on ecological systems

and living spaces by limiting global warming to 1.5°C; Through Global Compact Local Networks, it also allows signatory companies in different countries to access global best practices and learn from each other.

## We Contribute to Sustainability with Our Webinars

### On Father's Day we talked about Work-Life Balance from a Gender Equality Perspective

In our webinar held on Monday, June 20, with the participation of Sinem Hun, founder of Genderscope, we talked about the connection between work-life balance and gender inequality and the effects of this balance on different people. In the webinar, which attracted great interest from our participants; at the same time, we gained detailed information with case studies and touched upon the applications in businesses.

### We Discussed Gender Equality at Home on Mother's Day

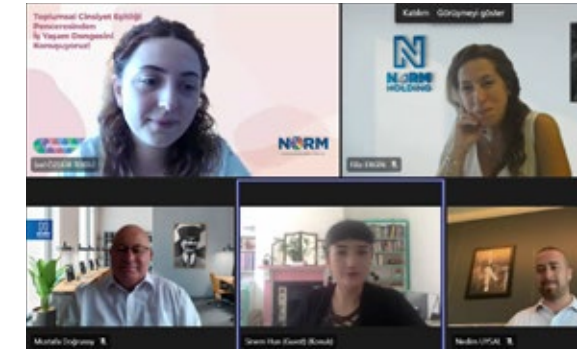

In our webinar with Industrial Psychologist Kiraz Öcal, we talked about our roles at home for a balanced home life and the roles attributed to the sexes from centuries ago. On Monday, May 9th, we had the opportunity to increase our awareness on roles for gender equality at home, while at the same time gaining practical information to improve the quality of our daily lives.

### We Met at our Sustainable Life Steps Webinar on World Environment Day



In the webinar we held on June 6 on the occasion of World Environment Day; we talked about the steps we need to take for a sustainable life with trainer Hale Acun Aydın. In our webinar, where we learned about how we can change our daily consumption habits; we had the opportunity to increase our awareness in the light of data on the benefits that small but practical steps will create on the road to sustainability.

### We held our Sustainable Supply Chain Stakeholder Meetings

We are aware of the importance of effectively managing the supply chain with a sustainability strategy, supporting sustainability across the entire value chain, and adopting a stakeholder-oriented approach.

To this end, we establish two-way communication with all our stakeholders. We keep our communication with our stakeholders open by using different dialog platforms and continue our efforts to achieve high communication rates that help us understand and meet the expectations of our stakeholders. We held sustainability best practice sharing meetings to better understand our stakeholders' expectations for a sustainable supply chain and to develop together by sharing best practices. Thanks to these meetings, we had the opportunity to discuss new collaborations and opportunities for improvement.

# SUSTAINABLE TOMORROW CANNOT EXIST WITHOUT US



## We Participated in World Cleanliness Day

On September 17th, World Clean-up Day, we were at Inciraltı Urban Forest as Norm Holding volunteers together with Let's Do It Turkey

Together, we collected the garbage in the forest and made the environment cleaner, making it a wonderful event worthy of World Clean-up Day.

We would like to thank all our colleagues who participated in the event and contributed to a sustainable future.

## We Completed the First Round of One-on-one Meetings

We have completed the first round of our One-on-one Meetings, where we are informed about all the developments within Norm Holding, listen to our company targets and important topics from our leaders, and convey our demands and suggestions directly to our leaders.

We organized our One-on-one meetings with different participants a total of 45 times with 11 teams and 34 face-to-face meetings and managed to reach all our colleagues



**bizbize**



We would like to thank all our leaders and colleagues who participated in the meetings and contributed to the transfer of knowledge and to our achievement of a better tomorrow.

As Norm Holding, we came together with our Sustainability Ambassadors in the workshop we organized within the scope of "Sustainability", which constitutes our roof strategy and is one of our most important priorities. On November 22nd at the Best Western Hotel, we had the opportunity to evaluate our work in 2021 and discuss our goals for the coming period.

We would like to thank all our colleagues who contributed to Norm's Sustainability journey by participating in our workshop led by our Sustainability Committee and leaders.

## We Discussed Sustainability in All Aspects at Ford Otosan's BIG 2022 Symposium.

The Information Communication Development (BIG) 2022 symposium, organized annually by Ford Otosan and attended by suppliers, universities, companies, and participants from Otosan,



was held on November 29-30 this year with the theme of "Sustainability".

As Ford's sole supplier of fasteners, we were invited to the "Supplier Panel" session of the event, where we took part as a speaker together with Brisa

We would like to thank our colleagues for participating in the event and enabling us to share our Sustainability Journey and Goals,

## Monthly Meetings with our Sustainability Working Groups Started

In December, we held meetings with our R&D and Innovation, Environment, People and Society, Digital Transformation and Corporate

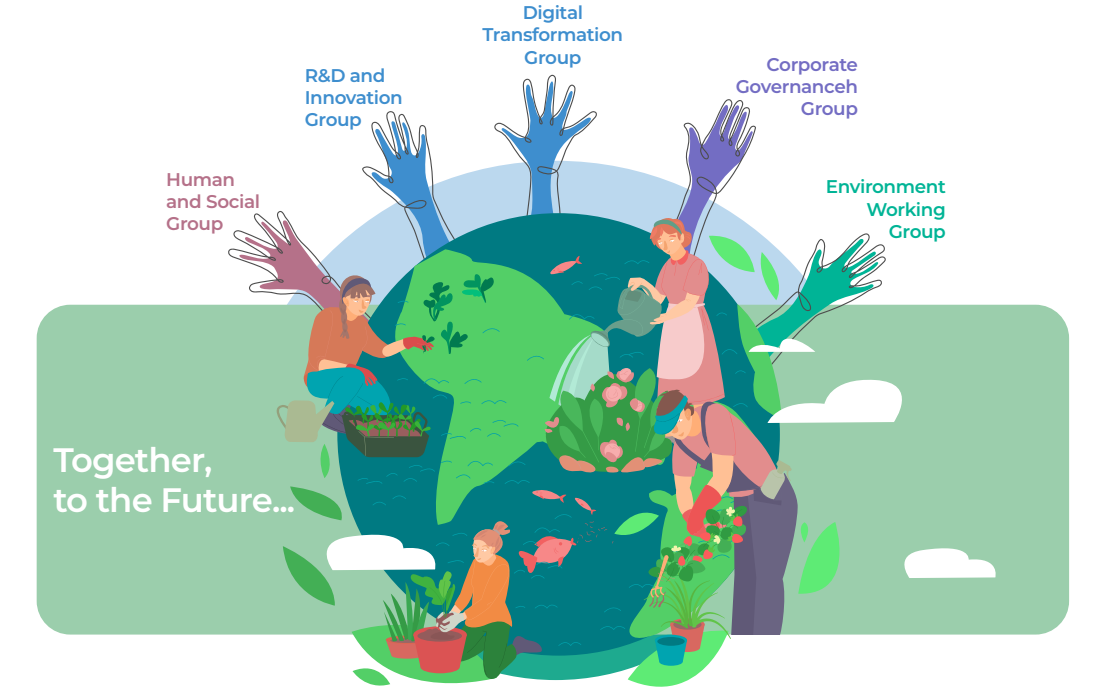

Governance working groups where we shared our annual work plan, discussed our activities to be held during the year and determined the distribution of tasks.

We will continue to come together on a monthly basis in our meetings where we will brainstorm on new practices to be integrated into our companies and ensure the dissemination of good practices across business units and functions.

### We took part in the event “Treasure Hunt”

#### Tim Regional Sustainable Export Mobilization Training Program

TIM Regional Sustainable Export Mobilization Online Training Program was organized

to raise awareness within the scope of the Sustainability Action Plan prepared by the Turkish Exporters Assembly (TIM).

Our Sustainability Committee Chair Duygu Uysal Simrooğlu participated as a guest in the webinar, which was the second online training of the program to be supported



by regional training sessions and held specifically for the Aegean Region.

The webinar held on 27 December focused on the Ministry's Implementation and Support Programs in the Field of Environment and Climate Change, Greenhouse Gas Calculation for Exporters, Green Energy and Sustainability, Industrial Symbiosis in Izmir Region, Increasing Institutional Capacity on Adaptation to Climate Change and Good Practice Examples.

### Our “N'DigiCard” Digital Business Card Application Started!

The use of N'DigiCard, our Digital Business Card Application designed by our Digital Transformation working group within the scope of the “Paperless Office Project”, has started.



With the mobile application developed with the contributions of our Norm Digital team, we will be able to easily create business cards by downloading the application to our mobile phones. At the same time, business cards can be shared as QR codes or “VCF” via online platforms such as WhatsApp and e-mail.

We are proud to share that by moving our business card usage to digital, we save 6 trees every year, while saving 60 kg of greenhouse gas and 1410 kwh of energy annually.

### 6. We Participated in POSCO Green Materials Forum 2022

As a thank you from Posco to its customers, we were invited to the 6th POSCO Green Materials Forum 2022 customer appreciation event in Incheon, Korea from October 31 to November 2, 2022. This year the theme of the biennial forum has been expanded to include sustainability, i.e. environmentally friendly materials. With the vision of being a trusted business partner that grows with its



customers for a sustainable future, POSCO aims to transform the forum into a platform for sharing and discussing sustainability-related industry trends and the latest technologies in the materials business.

#### Sustainability Workshop 2022

As Norm Holding, we came together with our Sustainability Ambassadors at the workshop we organized within the scope of “Sustainability”, which forms our umbrella

strategy and is one of our most important priorities.

At the event we held at the Best Western Hotel on November 22, we had the opportunity to evaluate our work in 2021 and also talk about our goals for the coming period.

By attending our workshop led by our Sustainability Committee and leaders, Norm's Sustainability

We would like to thank all our colleagues who contributed to our journey.



# Collaborations and Initiatives

## MEMBER ORGANIZATIONS

ARUSDER (Vehicle and Onboard Equipment and Work Machines)	İZMİR METROPOLITAN MUNICIPALITY / İZMİR ECONOMIC DEVELOPMENT BOARD
BESİAD (Fastener Industrialists and Businessmen's Association)	İZMİR ÇİĞLİ ROTARY
ÇEV-MER	İZMİR CHAMBER OF COMMERCE
EBSO	KALDER
EBSO - 44th Group Other Metal Products Industry Professional Committee	KIT-VAK FOUNDATION
EBSO FOUNDATION	(WINDOW MANUFACTURERS QUALITY ASSOCIATION)
AEGEAN EXPORTERS' ASSOCIATIONS	SALİHLİ OİZ
AEGEAN EXPORTERS' ASSOCIATIONS FERROUS AND NON-FERROUS METALS	SALİHLİLER CULTURE AND SOLIDARITY ASSOCIATION
EGİAD (Aegean Young Businessmen Association)	TAIDER (Turkey Family Business Association)
ESİAD (Aegean Industrialists' and Business People's Association)	TAYSAD (Automotive Suppliers Association of Turkey),
IYTE (İzmir Institute of Technology)	TEV (Turkish Education Foundation)
IAOSB FOUNDATION	TİM
İMSAD (Construction Materials Industrialist Association)	TOBB
İZMİR ATATÜRK ORGANIZED REGIONAL DIRECTORATE	(TÜSİAD) Turkish Industrialists and Businessmen's Association

Believing in the importance of sustainable development, we are committed to the ten fundamental universal principles of the Global Compact. As Norm Holding, we are not only signing the agreement, but we are also aware of the responsibility that our membership brings.

In order to support the work of Global Compact Turkey, we participated in the signing ceremony organized for the institutions from Turkey to join the UN Global Compact for the 2021-2022 period. On March 25, 2022, Duygu Uysal Simrooğlu, Member of the Board of Directors and Chair of the Sustainability Committee, signed on behalf of our company.

With this important event, we emphasized our commitments and contributions to sustainability.

# Stakeholder Relations

We recognize and embrace the importance of the Stakeholder Capitalism Indicators created by the World Economic Forum (WEF). Together with our sustainability strategy, we emphasize effective management of the supply chain, supporting sustainability in our entire value chain and the importance of a stakeholder-oriented approach.

In line with our goal of developing an open, transparent, and constructive relationship, we aim to balance the interests, needs and expectations of our stakeholders with the best interests of Norm Holding. In the context of sustainability, we identify the issues we focus on by seeking the opinions of our stakeholders and conduct stakeholder analyses at regular intervals.

We have a wide network of stakeholders in the sectors in which we operate. Each company determines and implements its own stakeholder communication strategies,

taking into account the unique needs and dynamics of the company. For this reason, stakeholder communication strategy and priorities for group companies vary according to the dynamics of the sector. Each of our companies creates different stakeholder communication maps according to their own way of doing business and priorities.

We are able to identify risks and opportunities to enhance our performance in a timely manner and maintain two-way contact with all of our stakeholders by using engagement platforms where we routinely communicate with our stakeholders. We aim to be in constant open communication with our stakeholders by using different dialog platforms.

Below is the consolidated stakeholder communication matrix for the Holding in general.

Stakeholder Group	Communication Frequency	Dialogue Platform
Employees	Every weekday	Mailing (Euromessage)
	Every weekday	Intranet (mobile and web)
	1 in 3 months	N'Haber magazine
	Every day	Screens
	1 in 2 years (DGA)	Employee engagement research and surveys Surveys on different topics issued every month
	1 in 3 months	Focus groups
	Every month	Reward system (seniority rewards)
	4 times a year	Performance Management System (PMS)
Media	1 a year	Annual report and sustainability report
	2-3 per month	Press releases
	1 per month	Interviews and talks
	1 in 2 months	Meetings and talks
	When necessary	Special case statements
Vocational Schools, Universities and Academia	Continuous	Training and technical support
	Continuous	Sponsorships
	1 per year	Annual report and sustainability report
	Continuous	Academic congresses and seminars
	Continuous	Meetings and talks
	Continuous	Joint projects
	Continuous	Articles and publications
Norm Holding Companies	Continuous	Joint research
	Once a year	Annual report and sustainability report
	Continuous	Working groups
Public Institutions	Continuous	Project partnerships
	Once a year	Annual report and sustainability report Audits
	When necessary	Meetings and talks
	When necessary	Training
Suppliers and Subcontractors	At least once a year	Joint projects (TUBİTAK-İMM)
	Once a year	Annual report and sustainability report
	When necessary	Norm Holding Code of Conduct
	When necessary	One-on-one interviews
	1 in 2 months	OHS committees
	Continuous	Award ceremony
Non-Governmental Organizations	Once a year	Training
	Continuous	Annual report and sustainability report working groups, committee, and board memberships
	Continuous	Memberships
	Continuous	Joint projects and initiatives
	Continuous	Meetings and talks

# Norm Holding and Sustainability: Future Matters



*We put forward our sustainability approach and commitments in four different areas that we have identified within the framework of value for the future.*



## The Foundations of Our Sustainability Approach

As Norm Holding, we have built our sustainability understanding on three pillars under the heading of Future Matters.

Our understanding of corporate governance, which we have expanded across our entire value chain, is our economic performance, which will allow us to build our common future in a more equitable and inclusive manner, and our integrated risk management, which will allow this performance to be displayed while protecting the planet and its resources and supporting climate action

Our aim is always to manage the positive or negative impacts of our products and services in the best way possible. Therefore, we evaluate our products and services from a holistic life cycle perspective.

### Work Matters



As Norm Holding, we continue our development by conducting effective risk and opportunity analyses with stakeholder participation, in accordance with the ESG (Environment, Social, and Governance) criteria, which serve as the foundation for the global understanding of responsible investing.

Developing the value we create as a result of our activities in a way that satisfies the needs and expectations of our customers and presenting it to our stakeholders in a quality and secure manner is our primary objective and the driving force behind this objective. With our “Work Matters” business strategy, we aim to reduce input-based emissions, support the development of suppliers, increase operational excellence and efficiency, boost customer satisfaction, conduct ESG assessments of all investments with a responsible approach, and communicate our ethical business understanding to our stakeholders through a corporate governance compliance report.

*We focus on equal opportunity, gender equality and diversity*

and inclusive workplace for all employees and extending it throughout our entire value chain.

We aim to achieve and document the Zero Occupational Accident target in all of our fields of activity in our “**Human Life Matters**” business approach, to put the corporate commitment of all our employees on an objective ground, and to create an inclusive and equitable opportunity environment for everyone by increasing their talents and competencies in line with the needs of the future.

### Planet Matters



As Norm Holding, we are aware that climate change poses the greatest threat to humanity. Supporting climate action is the way to control this change without disrupting the natural balance of the planet or accelerating the loss of biodiversity.

We plan our activities to prevent climate change and ensure the climate resilience of our value creation and sharing activities against potential changes, we make strategic applications in this direction, and we monitor and report our performance.

In our “Planet Matters” business approach, we aim to provide active participation and support in the global fight against climate change, reducing carbon footprint and other emissions in all scopes, accelerating efforts for energy efficiency, protecting fresh water, and, as a result, more effectively

implementing waste management.

### Technology Matters



We recognize the importance of developing a business understanding based on scientific foundations in order to solve the problems that threaten our common future. As a result, we conduct all of our activities in accordance with scientific facts.

We pay attention to scientifically explained issues and set clear targets to enable the achievement of common goals when planning and managing our activities. While we are developing our technology, we are also concerned with adapting to the digitalizing world, and we are constantly working in this direction.

In our “Technology Matters” business approach, we focus our R&D and innovation efforts on providing our stakeholders

with access to more efficient and durable products, as one of the facilitators of the transition to a low-carbon economy, and for this purpose, we are constantly improving and digitizing our technology, as well as aligning with the global market

### Human Life Matters



We believe in the importance of achieving sustainable development success, of creating an ecosystem that understands and meets future expectations and needs, and of supporting the human development of all stakeholders in our value chain, particularly internal stakeholders in this environment.

We recognize that it is our corporate responsibility to assist each stakeholder in our value chain in developing their unique talents and competencies. We fulfill this responsibility by fostering a more equitable

# FUTURE MATTERS

GRI: 102-46

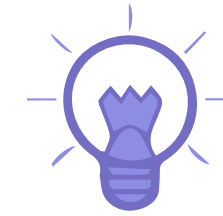

## Work Matters

Responsible Investments

Customer Expectations and Satisfaction

Product Quality and Safety



## Planet Matters

Climate Crisis

Water and Waste Management



## Technology Matters

Digitalization and Automation

R&D and Innovation

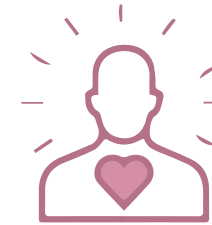

## Human Life Matters

Talent Management

Equal Opportunity and Diversity

Occupational Health and Safety

## FOUNDATIONS

CORPORATE GOVERNANCE

ECONOMIC PERFORMANCE

INTEGRATED RISK MANAGEMENT



## Sustainability Management

We carry out sustainability management through the “Sustainability Committee” established directly under the Board of Directors. This committee plays an important role in the planning, management, and implementation of sustainability efforts.

In Norm Holding and its affiliated companies, the management and responsibility of “sustainability” activities belongs to the Sustainability Committee. The Sustainability Committee is managed by a team of experts in the field of sustainability. This team contributes to the determination of the company’s sustainability strategy by regularly following national and international sustainability trends and developments.

The Sustainability Committee is coordinated by the “Sustainability

Specialist”. The Committee consists of at least 3 members selected from the members of the Board of Directors and advisors to the Board of Directors. These members contribute to the work of the committee based on their expertise in the field of sustainability.

The Sustainability Committee brings together different perspectives and develops strategies to meet the expectations and needs of various stakeholders. Committee members monitor the sustainability performance of the company, assess areas for improvement and make recommendations.

In addition to the members of the Board of Directors, other managers within Norm Holding and professional managers from related departments may also take place among the members of the Committee. In accordance with the functions of the committee, temporary members who are

experts in their fields and from outside the company may also participate in the committee.

Thanks to this diverse membership structure, the Sustainability Committee acts from an inclusive perspective and ensures effective and diverse engagement in the field of sustainability.

The Sustainability Committee has established a working group structure to make its work more effective and to ensure specialization in different subjects. These working groups focus on five different topics: R&D and Innovation, Environment, Digital Transformation, People and Society, Corporate Governance.

The Sustainability Committee regularly monitors the targets and progress set by the working groups.

In 2022, the committee included the CEO,

two Board members, a Board advisor, the Secretary General of the Board, and the Corporate Communications Manager. In December 2022, the position of Sustainability and Management Systems Director was created to manage the company’s sustainability efforts more effectively. As of December 2022, Management Systems and Sustainability Director and Strategy and Business Development Specialist have also joined the Sustainability Committee.

Detailed duties and responsibilities of the Committee are included in the “Working Principles of the Sustainability Committee” document available on Norm Holding’s website. You can access this document to review the working principles of the committee in more detail.

## NORM SUSTAINABILITY COMMITTEE AND SUB-WORKING GROUPS STRUCTURE

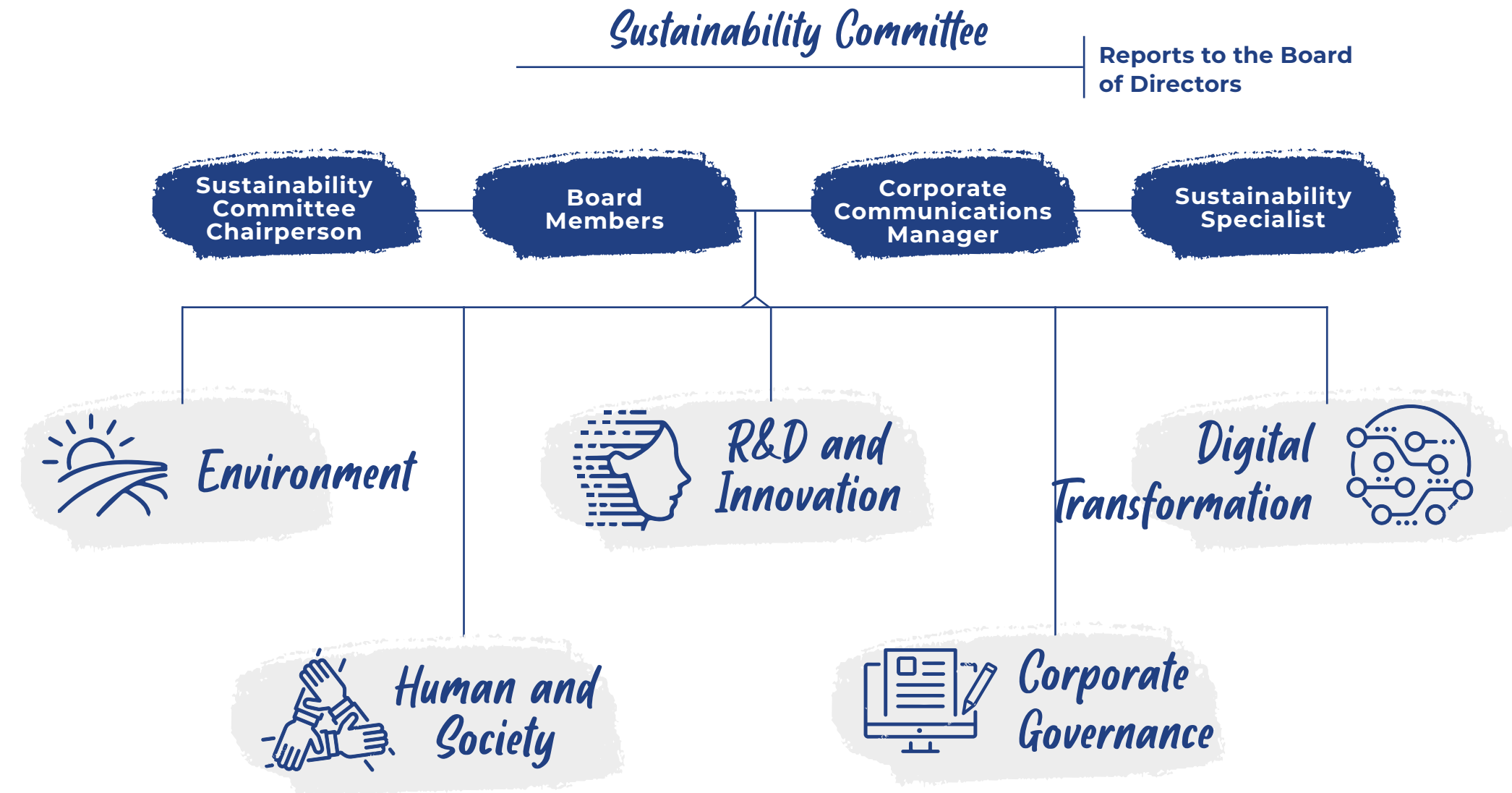

In 2022, we set our sustainability roadmap and took many steps on this journey throughout the year.

- The Committee convened 25 times in 2022 and continued its work in constant communication.
- The Committee contributed to the preparation of Norm Holding 2022 Sustainability Report to strengthen Norm Holding's sustainability performance.
- The Committee supported the operations by initiating carbon footprint measurements for the first time in Norm Holding and affiliated companies.
- Norm Holding carries its sustainability commitment to international platforms.
  - The Committee prepared the UNGC Communication on Progress (CoP) report and uploaded it on the UNGC website.
  - Committee Chair Duygu Uysal Simrooğlu attended the 10th Ordinary General Assembly of UNGC Turkey and participated in the UNGC Climate Ambition Accelerator program.
  - Committee member Demet

Yeşilaltay actively participated in the "Diversity and Inclusion Workshop" organized by the UNGC.

- The Committee determined KPIs (Key Performance Indicators) to monitor Norm Holding's sustainability performance.
- The Sustainability Committee organized training sessions to raise sustainability awareness within the company, raised employee awareness on sustainability issues and integrated them into the corporate culture.
- 2021 Norm Holding Sustainability Report was published.

Norm Holding Sustainability Committee carried out important works in 2022 and strengthened the company's performance in the field of sustainability. The committee's efforts demonstrate the company's commitment to ethical values and commitment to sustainability. Norm Holding aims to maintain its leadership role in the field of sustainability in the coming years and add new ones to its achievements.



### Sustainability Priorities

GRI: 102-43, 102-44, 102-47

We recognize the significance of basing our strategies and goals on issues that are key indicators of sustainability. We established Norm Holding's sustainability priorities in 2020, which will be in effect for two years. We created a multi-layered materiality matrix while conducting this study, which carried out the process of determining sustainability issues in accordance with the AA1000 Stakeholder Engagement Standard, knowing that Norm Holding has a large stakeholder network and many variables that affect its performance.

During this process, we completed the internal and external stakeholder mapping and defined all stakeholders' relationships with Norm Holding. We used

an online survey to collect feedback from internal stakeholders, international organizations in the external stakeholder category, universities, customers, NGOs/associations, financial institutions, and suppliers. We collected feedback from our stakeholders through online questionnaires.

In addition to stakeholder feedback, we analyzed global sustainability trends in the analysis. The 11th Development Plan, the European Green Deal, the Sustainability Accounting Standards Board (SASB) priority issues prepared specifically for sectors, and the Sustainable Development Goals Industry Index, as well as the priority issues of similar local and global companies, are among these trends. Besides, we examined the stakeholders' top priorities,

taking into account the report we prepared as part of the Norm Holding strategy and Leadership Workshop. As a result, the Norm Holding sustainability priorities matrix, which we developed, serves as the foundation for our business model.

In 2022, our material issues were re-evaluated by the Sustainability Committee to update them. In this way, we remain committed to our goal of continuously improving the sustainability performance of our holding.

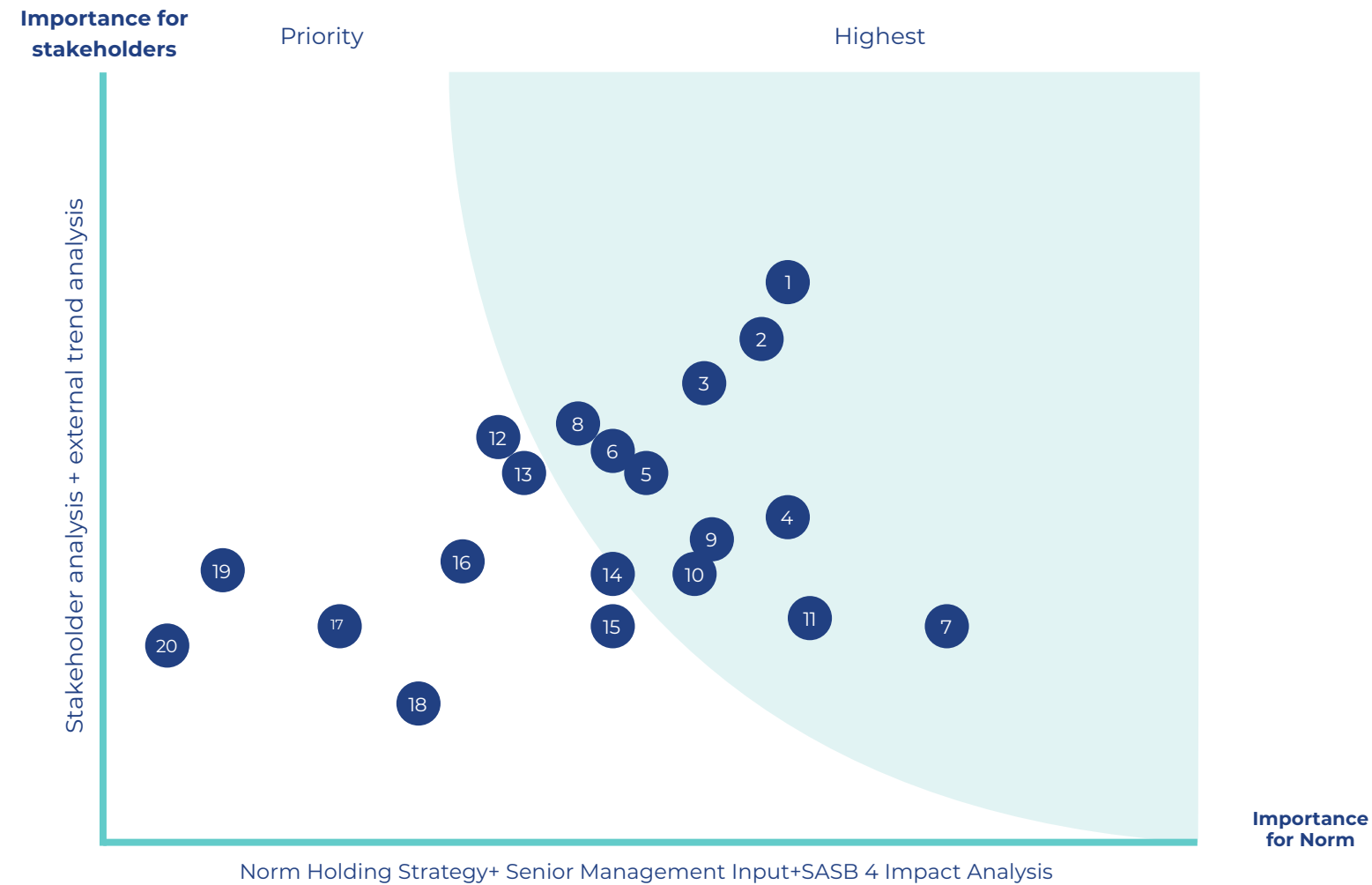

- 1 Climate Change and Energy Consumption
- 8 Water and Waste Management
- 15 Risk Management
- 2 Product Safety and Quality
- 9 Customer Expectations and Satisfaction
- 16 Work Ethic
- 3 R&D and Innovation
- 10 Responsible Investment Approach
- 17 Multi Stakeholder Initiatives and Collaborations
- 4 Operational Excellence and Efficiency
- 11 Corporate Governance
- 18 Contribution to Local Socioeconomic Development
- 5 Occupational Health and Safety
- 12 Esponsible Resource Management and Procurement
- 19 Biodiversity
- 6 Talent Management and Employee Loyalty
- 13 Human Rights and Fair Work Conditions
- 20 Community Investments
- 7 Digitalization and Automation
- 14 Equal Opportunity and Diversity

Priority Level	Issue	Associated SDGs	How we manage
Highest	Climate change and energy consumption		In the scope of combatting climate crisis, we are working to reduce greenhouse gas emissions and achieve a carbon neutral state. In this context, we invest in energy efficiency and renewable energy sources, identify climate risks, and measure their impact on our business.
	Product safety and quality		We adopt high product safety standards so that our customers always have access to safe products, also develop projects and applications for the protection and development of product quality standards.
	R&D and innovation	4 QUALITY EDUCATION	Innovative and responsible products and production are significant. To this aim, we invest in R&D and develop products that meet the today and future needs of our clients.
	Operational excellence and efficiency	7 AFFORDABLE AND CLEAN ENERGY	By improving business processes and operations, we emphasize efficiency, increase our competitive advantage while reducing our environmental impact.
	Occupational health and Safety	8 DECENT WORK AND ECONOMIC GROWTH	Protecting the physical and mental health of employees in all business processes is among the most important issues for both our business and our employees, who are our most valuable stakeholders. We take the necessary measures to provide a healthy and safe work environment.
	Talent management and employee engagement	9 INDUSTRY, INNOVATION AND INFRASTRUCTURE	We are working to hire and retaining next-generation talents, and to develop them through personal development and career planning practices. In that regard, we regularly measure the loyalty and satisfaction of our employees and carry out projects and practices to enhance them.
	Digitization and automation	12 RESPONSIBLE CONSUMPTION AND PRODUCTION	Digitalization and automation play a vital role in increasing efficiency and safety in all processes. As Norm Holding, we both invest in new technology and digitalization, and increase automation in all business processes.
	Water and waste management	13 CLIMATE ACTION	In our production-based business model, we adopt the "Zero Waste" approach and aim to recycle and reused. We also aim to reduce the consumption of water and other valuable natural resources and to prevent environmental pollution.
	Customer expectations and satisfaction		We collect the expectations and feedback of our customers, one of our most important stakeholders, through effective communication channels, and ensure that satisfaction is kept high with quality products/services.
	Responsible investment approach		We aim to preserve environmental, social, and corporate governance principles in new investment decisions. In the new products and services, we develop, we focus on social and/or environmental benefits.
Corporate governance		We adopt fair, transparent, accountable, and responsible corporate governance.	

Priority Level	Issue	Associated SDGs	How we manage
Critical	Responsible resource management and procurement		It is aimed to integrate environmental, social, and ethical conditions into the supply chain management, and monitor it; we also aim to develop our suppliers in our sustainability transformation along with us.
	Human rights and fair working conditions		Protecting employee rights along the entire value chain is an important issue for Norm Holding and its subsidiaries. In this regard, we care about preventing all kinds of discrimination and creating a fair and equal working environment for everyone.
	Equal opportunity and diversity	5 GENDER EQUALITY	We consider equality of opportunity and diversity in the business environment, especially starting from recruitment processes. We do not discriminate based on religion, language, race, gender, ethnicity, sexual orientation, or disability.
	Business ethics	8 DECENT WORK AND ECONOMIC GROWTH	We manage Norm Holding and its subsidiaries with an ethical business approach and prevent unfair competition.
	Risk management	10 REDUCED INEQUALITIES	We continue our efforts to manage financial and non-financial risks in an integrated manner.
	Biodiversity	12 RESPONSIBLE CONSUMPTION AND PRODUCTION	Although the regions where we operate does not host a vast biodiversity, we care about the protection of all living species and habitats.
	Social Investment programs	17 PARTNERSHIPS FOR THE GOALS	We develop strategic and long-term social investment programs that benefit both the Holding and the society.
	Multi-stakeholder initiatives and collaborations		In 2021, we signed the United Nations Global Compact. We aim to continue to be a member of local and global initiatives and to establish collaborations for the creation of value on a larger scale in the field of sustainability.
	Contribution to local socioeconomic development		We contribute to development by creating employment in the regions where we carry out all our operations, especially in Izmir and its surroundings.

\*In 2021, the material issues were re-evaluated and updated by the Sustainability Committee, and although the issue of "Equal Opportunity and Diversity" appeared in the priority group, it was evaluated in the high priority issues group by the committee's decision.

# Life Cycle

Our aim is always to manage the positive or negative impacts of our products and services in the best way possible. Therefore, we evaluate our products and services from a holistic life cycle perspective.

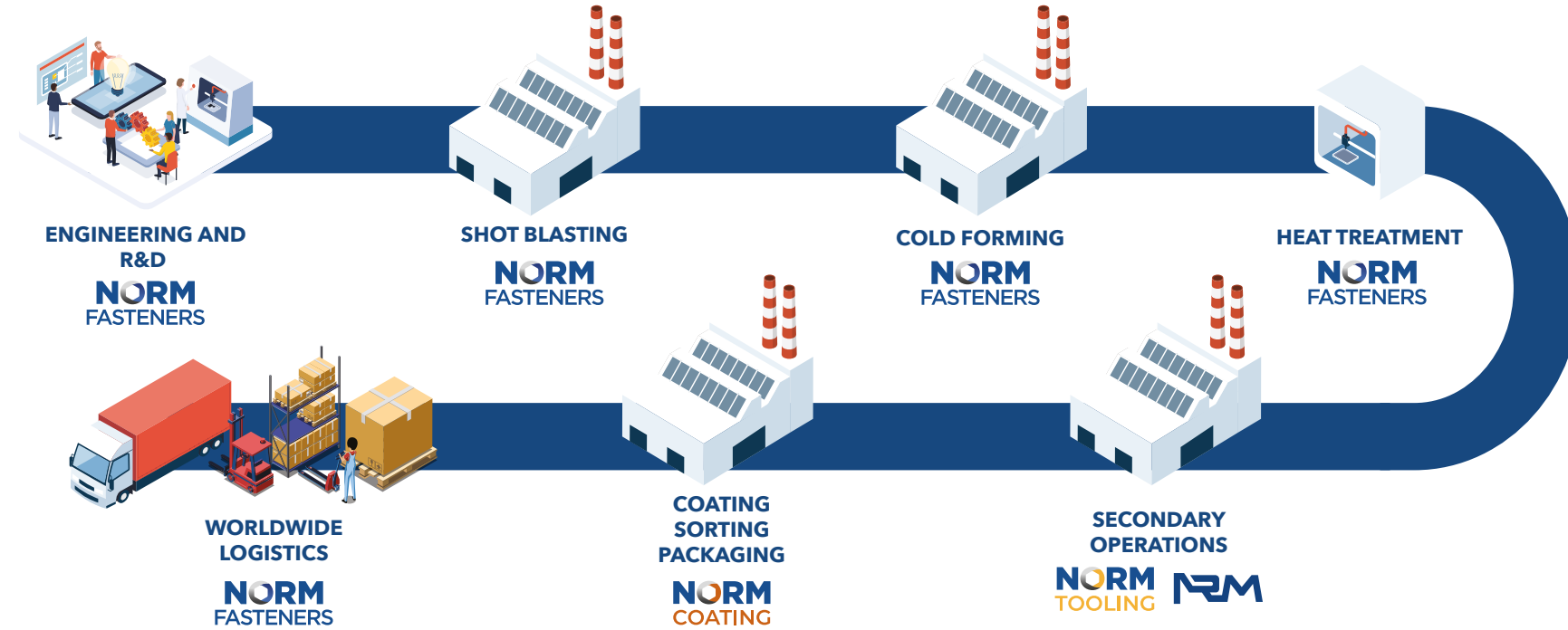

# Future Matters Chain

GRI: 102-49

As Norm Holding, we are objectifying and implementing the four main focus areas of our sustainability understanding in a manner that has become pervasive across our value chain. We monitor our performance in our focus areas by expanding its scope day by day throughout our entire value chain, we measure and report by setting measurable key success targets.

## NORM HOLDING VALUE CHAIN

GRI: 102-49

NORM HOLDING APPROACH AND INPUTS	VALUE GENERATION AND PERFORMANCE	OUTPUTS	SUSTAINABLE VALUES
<p>We strive to ensure that our corporate goals, business ethics and service production quality objectives are clearly understood throughout our value chain, and ultimately to ensure customer satisfaction and loyalty, we track and improve our performance on a daily basis</p>		<p>We aim to comply with the waste and energy management principles required to protect fresh water, our most limited resource, to reduce all environmental impacts of our activities, as well as to be climate neutral, the framework of which is determined by scientific studies. We give priority to providing the competencies and competencies that all our stakeholders in our ecosystem, especially our sector, will need to survive in the future shaped by developing technologies.</p>	
<p><b>Planet Matters</b></p>	<p>We take care to ensure that all production inputs required to carry out our activities are produced in a way that will contribute to the protection of the delicate balances of the planet, its healthy and safe supply, and the fight against climate change.</p>	<p>%100 Non-hazardous Waste Recycling 3000 MWh Solar Energy Production Energy Consumption and Efficiency Water and Waste Management Combating Climate Change and Resilience</p>	<p>70 Million TL Environmental Investment Complaint with Planet Support for Development</p>
<p><b>Human Life Matters</b></p>	<p>We pay utmost attention to the unconditional implementation of occupational health and safety both in our businesses and in all actors of our eco and social system that affect and contribute to the activities of these businesses, and to create an equitable and inclusive work environment for everyone.</p>	<p>%23,1 Female Management Position %35,6 Female Office Employees 42.654 hours of OHS training Talent Management and Employee Loyalty Equal Opportunity and Diversity</p>	<p>3.500+ Employees Equality and Inclusion Contribution to Employment</p>
<p><b>Technology Matters</b></p>	<p>We strive to ensure that all our processes are fed with the most advanced technology in the part of our value chain from raw materials to our warehouses, which are under our direct managerial control, and that the remaining parts before and after are digitalized and harmonized.</p>	<p>5 R&amp;D and Design Center 13.500 hours of additional labor with «Normie» R&amp;D and Innovation Digitalization and Automation 110 Million TL R&amp;D and Digitalization Investment</p>	<p>13 Registered Patents 6 Utility Models 6 Industrial Design Technological Progress</p>
<p><b>Work Matters</b></p>	<p>By analyzing tomorrow's needs today, we take care to meet the needs and expectations of our customers with the responsible investments we make in our value chain and to provide this with high quality and safe products and services.</p>	<p>9 Countries, 23 Companies 18 Production and 15 Logistic Centers Product Safety and Quality Operational Excellence and Efficiency Responsible Investing</p>	<p>Export to 50+ countries 12 Awards! ve 2200+ Customers Contribution to Global Economy Customer Satisfaction</p>

# Goals

GRI: 102-49



## Planet Matters

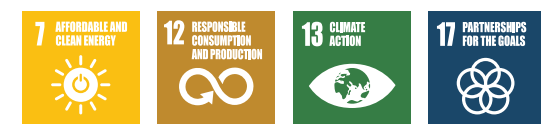

High Priority Issues	Holding Goals	Goal Year	Progress
Climate Change and Energy Consumption	Net zero emissions target-Scope 1 and 2 emissions	2050	In 2022, we calculated our Scope 1 and Scope 2 emissions and analysed our environmental impact during the reporting period. We measure our carbon footprint at 25 campuses (21 in Turkey and 4 abroad) and 13 companies. In 2023, the decarbonization roadmap will be completed and shared with our stakeholders.
	Reduction of carbon footprint emissions by 50% by 2021 - Scope 1 and 2 emissions	2030	
	Increasing renewable energy production by 100% in Salihli campuses and 50% in Izmir campuses compared to 2021	2030	In 2022, we generated more than 3 million kwh of renewable energy through investments in solar power plants with an installed capacity of 3.9 MW in Izmir and Salihli. For 2023, we have planned to invest in 30.6 MW SPP and 7 MW WPP. We have initiated and are continuing EIA processes for Solar Energy Farm investments. We invested a total of 4 million euros in "production track renewal", "energy efficiency" and "renewable energy". We continue our studies
	Increasing energy efficiency	2030	With the heat obtained by the recycling method in the heat treatment line, we ensured the heating of a total area of 55,000 m2.
	Reducing energy consumption per production	2030	
	Zero coal consumption	2030	In 2023, decarbonization roadmap studies are targeted on the basis of fossil fuel consumption reduction and energy efficiency.

High Priority Issues	Holding Goals	Goal Year	Progress
Water and Waste Management	Zero Waste target (hazardous and non-hazardous waste)	2050	Since 2021, we have recycled 734.7 tons of paper waste through Zero Waste practices. This is equivalent to 12490 trees, 1836.7 m <sup>3</sup> of storage space savings, 3012261.8 kwh of energy savings, 20571.5 m <sup>3</sup> of water savings and 130 tons of CO <sub>2</sub> equivalent greenhouse gas emissions.
	Reducing the amount of water withdrawn per product in production facilities compared to the base year 2020	2030	In 2022, we started the process of monitoring the reductions related to the conversion of water towers used in flaring processes to air-cooled systems. We continue to work on the transition of our existing water towers to air-cooled systems in water-using systems
	Increasing the water recycling and reuse rate to 50% compared to the base year 2020	2030	
	Reducing the total amount of waste per product	2030	
	Providing 50% reduction in packaging waste	2030	In 2022, we started the process of packaging waste reduction and waste recovery. Packaging materials continue to be created from recyclable and recyclable materials.
	Increasing waste recovery to 90%	2023	
	Completely eliminating the use of disposable plastic and disposable cups in the office	2025	In 2022, we took action to completely eliminate the use of single-use plastic and disposable cups in the office. We continue our studies

# Hedefler



## Human Life Matters



High Priority Issues	Holding Goals	Goal Year	Progress
Equal Opportunity and Diversity	Increasing the rate of women employees 50% of women working in STEM positions, 30% of women working in senior management, 35% in lower management positions, 33% in all management positions	2030	<p>Our target for women working in STEM positions is 50%. As a result of the steps taken towards this goal, the rate of female employees increased from 20% in 2021 to 24% in 2022.</p> <p>Our target for the proportion of women working in senior management is set at 30%. However, this rate dropped from 25% in 2021 to 24% in 2022. We have ongoing efforts to reach the goal.</p> <p>The target rate of women working in lower management positions is set at 35%. As a result of the steps taken towards this target, this rate increased from 23% in 2021 to 26% in 2022. The target for the proportion of women working in all management positions is set at 33%. As a result of the steps taken towards this target, this ratio, which was 23% in 2021, increased to 25% in 2022.</p>
	Being a signatory of the UN Women Empowerment Principles	2025	In 2022, we started working to fulfill the requirements to become a signatory of the UN Women Empowerment Principles in order to reach our goal for 2025.

High Priority Issues	Holding Goals	Goal Year	Progress
Occupational Health and Safety (OHS)	Zero work accidents		We continue our improvement projects to reduce Occupational Health and Safety (OHS) accidents to zero.
	Creating an employee welfare and well-being program	2023	In 2022, we conducted interviews with companies that provide psychological counseling to employees at any time. The process is currently in the planning phase.
Talent Management and Employee Loyalty	Increasing the work-life balance score in the Norm Employee Opinion Survey	2023	In 2022, voluntary action committees were established in our company based on the results of the Employee Opinion Survey conducted in 2021. By assessing each factor, these committees identified actions to be implemented company-wide and rigorously monitored the implementation of these action plans throughout 2022.
	Increasing employee loyalty rate	2025	
	Working on an Agile organizational structure	2024	Benchmark analyses on agile organizational structure were conducted and interviews were held with companies providing consultancy on this subject.
	Planning developments in line with individual development plans	2023	In 2022, all white-collar employees at Norm were included in the potential assessment conducted by our business partner for an objective evaluation process. As part of this process, the definition of potential for Norm Holding was first identified through workshops. Employees in specialist roles participated in the Potential Inventory, while those in management roles were included in the Assessment Center. Each employee participated in feedback sessions with counselors and created their individual development plans after this process. These development plans are monitored by the employee, his/her manager, and human resources.

# Hedefler



## Work Matters



High Priority Issues	Holding Goals	Goal Year	Progress
<b>Product Safety and Quality</b>	50% reduction in emissions from input products	2030	Once our responsible procurement policy is published, a communication plan will be implemented in 2023 to communicate these policies to suppliers and a Supplier ESG assessment and development program will also be launched. This program will include ESG assessment and collection of carbon emission data from suppliers. Training programs will be organized to support low scoring suppliers and help them reach a certain level.
	Ensuring zero defect in the product	2025	
	Reducing poor quality costs	2025	
	Establishing a supplier development program	2024	
	Evaluating supplier sustainability (ESG) performance	2023	
<b>Operational Excellence and Efficiency</b>	Increasing efficiency in production	2025	Üretim verimliliğini artırmaya yönelik projeler üzerinde çalışmalarımız devam etmektedir.
	100% compliance with the production plan	2025	Üretim planına %100 uyum sağlamaya yönelik projeler üzerinde çalışmalarımız devam etmektedir.
<b>Customer Expectations and Satisfaction</b>	Increasing the customer satisfaction rate	2030	In the satisfaction survey conducted in 2022, we succeeded in raising the satisfaction score of our domestic and foreign customers from 4.08 to 4.2 points out of 5. In addition, our net recommendation score was 38% in the Customer Satisfaction Survey. We continue our studies
	Increasing customer loyalty	2030	
	Increasing the number of engineering offices	2025	We are moving towards the goal of increasing the number of engineering offices to 3 by 2025. In 2022, we reached 33% of this target and increased the number of offices to 1.
<b>Responsible Investment Approach</b>	Making an ESG assessment during investment	2024	We successfully completed the goal of conducting an ESG assessment during the investment process.
	Creating a responsible purchasing policy	2023	We successfully completed the target of preparing a Corporate Governance Principles compliance report.
<b>Corporate Governance</b>	Preparing a compliance report with Corporate Governance Principles	2023	Kurumsal Yönetim İlkeleri'ne uyum raporu hazırlama hedefini başarıyla tamamladık.
	Setting up the Enterprise Risk Management system	2023	Explained in the risk management section
	Identifying risk management metrics	2023	
	Developing ethical advice and reporting mechanisms	2023	We successfully completed the goal of improving ethical advice and reporting mechanisms.



## Technology Matters



High Priority Issues	Holding Goals	Goal Year	Progress
<b>R&amp;D and Innovation</b>	Increasing R&D spending to 2%	2030	In line with our targets, we increased our R&D spending to 1.2% in 2022. By 2027, we aim to increase this rate to 1.5%.
	Increasing the rate of sustainable product projects	2030	In 2022, we continued our planning efforts to increase sustainable product projects.
	Creating a roadmap for the transition to a low carbon economy: Products with low energy density, reduced weight, longer life	2023	In 2023, we will create a roadmap for transition to a low-carbon economy, targeting products with high energy intensity, reduced weight, and longer life spans.
	Increasing intellectual and industrial rights applications	2025	In 2022, we came one step closer to our sustainability goal with 5 applications in the field of Intellectual and Industrial Rights. By stepping up our efforts in this area, we are moving steadily towards our target of 7 applications by 2025.
	Increasing the number of scientific publications	2025	In 2022, we took an important step towards our sustainability goal by increasing the number of scientific publications to 17. By 2025, we aim to reach 20 scientific publications.
	<b>Digitization and Automation</b>	Increasing the digital maturity level index	2025
Increasing RPA process automations		2025	Within the scope of RPA, a total of 103 process automations were realized between 2021 and 2022, saving 22 people's workforce.
Completing Digital Transformation Academy training sessions		2025	Digital Transformation Academy training sessions continued throughout 2022.

# WORK MATTERS

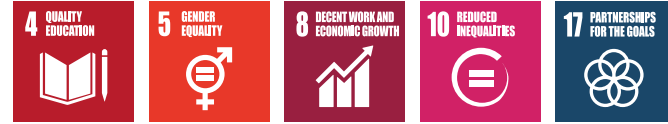

*We value work to support the transformation and development of society and the business world, especially our customers. While we ensure this transformation with high-value, high-quality, safe and innovative products, we support the development of the sectors and regions in which we operate, thanks to the responsible investment approach we adopt as the Holding.*



As Norm Holding, we attach great importance to supporting the transformation and development of the society and business world as well as our customers; we take care to ensure this transformation with our high value-added, high quality, safe and innovative products. We aim to contribute to the development of the sectors and regions in which we operate by adopting a responsible investment approach. With our highly qualified human capital with high corporate governance maturity and sectoral expertise, we focus on creating value not only in the business world but also for the welfare and progress of society.

We aim to create value for our stakeholders based on excellence and efficiency in production processes. We believe in the power of digital transformation and we carry out various activities in this direction. In this

way, we meet the needs and expectations of our customers by offering them higher quality and innovative products. We strive to minimize our environmental impact by achieving our sustainability goals through efficient production processes. With these efforts to move forward, we aim to provide value to our stakeholders and become a leader in the sector.

Under the leadership of our Sustainability Committee, in order to adapt to the developing world and to carry the added value we have provided so far to future generations, we are taking a step on a very difficult and enjoyable journey with our Corporate Governance working group by saying “Work Matters”.



# Responsible Investments



Our working groups consist of Sustainability Management, Corporate Governance, Risk Management, Business Ethics, Anti-Bribery and Anti-Corruption, Information Security, Customer Expectations and Supply Chain sub-working groups. The goal of these groups is to harmonise the management systems that Norm Holding has successfully implemented in the past with the concept of sustainability. In this way, we aim to increase the contribution we provide to all our stakeholders, the country, and the world economy day by day.

With the “Work Matters” business approach, we aim to support the development of suppliers by reducing input emissions and at the same time increase customer satisfaction. In line with this goal, we strive for operational excellence and increased efficiency, and we aim to

ensure that all investments are evaluated according to Environmental, Social and Corporate Governance (ESG) criteria and to convey our ethical business approach to our stakeholders through the corporate governance principles compliance report. As Norm Holding, with the “Work Matters” business approach, we launched a program in 2022 aiming end-to-end management of sustainability in the supply chain and evaluation and development of suppliers on sustainability issues. Within this framework, we have established our “Responsible Procurement Policy”. In 2023, we plan to launch our “Supplier ESG Assessment and Development” program.

We prioritize responsible investments in our portfolio as investors and work to make our current portfolio more responsible.

In 2022, we took important steps towards a “Climate Neutral” future. Thanks to investments in solar power plants, we generated more than 3,000,000 kWh of renewable energy in 2022. As of now, we have an installed capacity of 3.9 MW SPP in İzmir and Salihli, and we plan to invest 30.6 MW SPP and 7 MW WPP in 2023. With these investments, we aim to grow further and reduce our environmental impact with the goal of turning to sustainable and environmentally friendly energy sources.

We support sustainable transformation in industry and trade with our products and services.

*We support increased responsible investment in new sectors in our immediate vicinity, particularly in the Aegean region where we operate.*

# Customer Expectations and Satisfaction



In 2022, we attached great importance to customer orientation in order to respond to the needs of the sectors and continued our long-standing efforts focused on customer satisfaction. Compared to 2021, in 2022 our customer base increased by 55.7% and we serve 782 customers. 190 of our customers are domestic customers. We manufacture for a variety of industries, including the automotive main industry (OEM), domestic and international wholesalers, and consumer durables, primarily for corporate customers. In order to increase the quality of customer relations and maximise customer satisfaction, we implement the “ENLider Sensin” executive training programme. Through this special program, we train managers in customer relations, support them to understand customer expectations and adopt a customer-oriented approach.

We carry out our work with the importance we attach to digital transformation, and we aim to move the customer experience forward. We can quickly confirm orders and allow automatic order entry with our new customer portal, the dynamic software robot Normie.

As a result of our experience and the customer demands we have encountered over the years, we have conducted customer segmentation studies in order to provide a better Norm experience to our customers, and we have established the KAM (Key Account Management) department within our organizational structure, where the customers with the highest transaction volume are gathered. In this way, we were able to offer our customer-oriented service more effectively and efficiently.

The KAM department we created started to provide global services to our portfolio of customers, especially our OEM (Original Equipment Manufacturers) customers, from a single point of contact. In this way, we are able to provide a more personalized service to customers, better understand their needs and create more effective solutions to meet their expectations.

Our KAM department plays an important role in focusing on customers with high transaction volumes, providing them with customized solutions and strengthening our relationships. In this way, we increase customer satisfaction and establish a long-term and reliable cooperation with our customers. We increase our competitiveness in the market by offering customized services suitable for different customer groups.

We emphasize our belief in gender equality at all levels of society and the KAM team, 50% of whose employees are “women”, reflects this mission. The share of sales realized by the KAM team in turnover increased from 29% in 2018 to 31% in 2020 and 32% in 2021, despite the pandemic and various crises. In 2022, when the crises still persisted, we increased our turnover rate by 27% and successfully maintained our share of sales at 30% thanks to the right strategies and price policies.

# Customer Satisfaction Survey Results

Every year, Norm Holding conducts satisfaction and loyalty surveys that cover all of our customers in order to identify our strong and open areas and to ensure excellence in customer service quality, and we value our customers' opinions about us. We receive regular feedback from these surveys and make corrections in the areas where we are lacking. In the satisfaction survey conducted in 2022, we increased our score of 4.08 out of 5 in the satisfaction rate of our domestic and foreign customers, reaching 4.2 points. Furthermore, the net recommendation score in the Customer Satisfaction Survey was 38%.

We evaluate the results of the Customer Satisfaction Survey together with the Board of Directors and determine actions by comparing these results with previous

years and targets.

- Norm Fasteners Germany received an "A Performance Score" from all of the customers it served in 2022.
- As a result of the survey conducted with our customers by an independent research organization to evaluate the services of STD, which focuses on customer satisfaction in every link of the chain, in 2022, our "Domestic customer satisfaction rate" was successfully completed at 99%.
- According to the results of the Customer Satisfaction study we conducted for Norm Additive in 2022, our overall satisfaction rate was realized as 92%, above the targeted 80%.

Norm Holding protects the rights of stakeholders regulated by legislation and

mutual agreements within the framework of our Stakeholders Policy in its transactions and activities. During the period 01 01 2022 - 31 12 2022; there were no complaints / lawsuits with stakeholders.

Norm Holding Stakeholders Policy is available on the website [www.normholding.com](http://www.normholding.com).

## Customer Satisfaction Survey Results

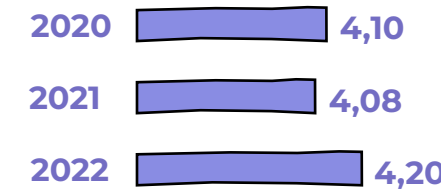

# Product Quality and Safety



Within the scope of the quality policy, we aim to continuously improve product quality to meet and exceed customer expectations. We take care to ensure high quality and safety conditions by using international management standard certificates.

We have 11 certificates in our Norm Fasteners Bolts company within Norm Fasteners. In addition to the existing certificates in our Norm Coating company, we received ISO 14001 Environmental Management System, ISO 45001 Occupational Health and Safety Management System and ISO 50001 Energy Management System certificates in 2022.

In 2022, STD received the "Authorized Economic Operator (AEO)" Certificate throughout Turkey. It became the 585th company to receive the "Authorized Economic

Operator Certificate", an international status that offers convenience and privileges in customs affairs to reliable companies that fulfill their customs obligations and meet other requirements, and the 44th company to receive "Export On-Site Customs Clearance". ST Trading completed ISO 9001 and ISO 14001 certifications in 2022. We included ISO 9001 Quality Management System certification for ST Trading Poland in our plans.

Our Norm Tooling company has started to work towards obtaining the IATF 16949 Automotive Quality Management System and AS 9100 certificate, which is important for the aviation sector, in 2023.

Norm Fasteners aims to obtain ISO 14001 Environmental Management System, ISO 45001 Occupational Health and Safety

*We go beyond the obligations arising from national legislation to ensure high quality and safety conditions*

Management System and ISO 50001 Energy Management System certificates in 2023 in Norm Nuts, Norm Salihli Screw and Bold and MS Screw companies.



# Product Quality and Safety

	IATF 16949	ISO 9001	ISO 14001	ISO 45001	ISO 50001	EN 14399-1	EN 15048-1	ISO 4032	ISO 4014	ISO 4017	TS EN ISO 13918	ISO 27001	YYS
Norm Fasteners	Norm Fasteners Bolts İzmir	X	X	X	X	X	X	X	X	X	X	X	X
	Norm Fasteners Nuts	X	X			X	X	X					
	Norm Fasteners Bolts Salihli	X	X						X	X			
	Norm Fasteners Screw	X	X										
	Norm Fasteners Bursa	X	X										
	Norm Fasteners Germany	X	X										
	Norm Fasteners America	X	X										
Norm Coating	Norm Coating	X	X	X	X	X							
	Norm Tooling	X	X										
	Norm Additive		X										
Norm Digital	Norm Digital											X	
	STD		X									X	X
	Norm Fasteners Romania		X										
Commercial Group	ST Trading		X	X									

## Customer Audits and Internal Audits

A total of 294 internal audits were conducted in 2022. In addition, 19 standard audits were conducted within the scope of Standard Audits. These standard audits include CE and TSE certifications, IATF 16949 and ISO 9001 certification audits.

In 2022, in addition to the documentation module, internal audits and nonconformity management started to be carried out through the QDMS system with the use of the audit module and action module.

In 2022, a total of 45 self-assessment requests were received from customers. In addition, requests for Reach and Rohs analysis reports or declaration notifications increased compared to 2021. While 54 declaration requests were received in 2021, the number of these requests increased to 80 in 2022.

# Operational Excellence

We focus on operational excellence in our business processes. We manage our business processes with a flexible and solution-oriented structure, keep our productivity at high levels and form the basis of our sustainable growth approach.

We aim to create value and maximize the level of service while optimizing the use of resources. For this purpose, we established Norm Holding Operational Excellence System to support the culture of continuous development. Our system is built on the following core values:

- Sustainability and standardization
- Maximum stakeholder satisfaction
- Continuous improvement
- Pioneering new applications in the sector
- Communication and team spirit

- Transparency
- Cooperation and Teamwork
- Maximum service level
- Innovation and Technology

Norm Holding Operational Excellence System guides us in improving our business processes and achieving operational excellence by operating in line with these values.

The Kaizen method, which we use to make continuous improvements in our factories, is carried out with the participation of all of our employees. Every quarter, our employees were rewarded for the suggestions they made and the kaizens they completed.

Workplace	Number of Suggestions	Number of Kaizen Completed	Number of Ongoing Kaizen
Norm Fasteners Screws	404	78	55
Norm Tooling	684	122	482
Norm Fasteners Bursa	2	1	1
Norm Fasteners Bolts İzmir	937	216	455
Norm Fasteners Bolts Salihli	834	120	126
Norm Fasteners Nuts İzmir	630	244	193
Norm Fasteners Nuts Salihli	933	225	170
STD Ankara	22	9	3
STD Dilovası	46	13	6
STD Center	114	36	15
Norm Coating İzmir	1118	288	611
Norm Coating Salihli	1312	379	333
<b>Total</b>	<b>7036</b>	<b>1731</b>	<b>2450</b>

# Supply Chain Management

GRI: 102-49

Being aware of the risks related to the supply chain and business practices, we fully comply with nationally and internationally recognized standard guidelines, directives, and responsible business practices, and conduct our business according to these principles. We reflect all updates to our activities and internal management system. In 2022, our industry and trade group collaborated with a total of 6,153 suppliers. We started business relations with 1,213 new suppliers in our industry group and 51 new suppliers in our trade group.

In 2022, 80.5% of payments to suppliers in our industry group and 88.0% of payments to suppliers in our trade group were to local suppliers.

We build relationships based on trust and respect through responsible supply chain management. We defend human rights and emphasize ethical and social responsibility standards. We cooperate with our suppliers and strive to reduce their

environmental and social impacts, and improve their environmental performance by developing sustainability-oriented projects. We establish fair relationships with customers and suppliers by emphasizing the confidentiality of commercial information. We integrate environmental management standards with our suppliers and focus on reducing environmental impact.

We continuously assess risks and opportunities in our supply chain and use various initiatives to ensure environmental, social and governance standards. We integrate our sustainable procurement practices with our procurement and management processes and act in cooperation.

In 2022, the revised Supplier Evaluation Procedure made environmental and social criteria part of the supplier evaluation. In order to become a Norm Holding supplier, suppliers must have a minimum ISO 9001:2015 certificate or a certificate accredited by an IAF MLA member according to the latest version of IATF 16949:2016.



Within the quality management system, we monitor issues such as product quality, delivery time and quantity performance, status of corrective actions, emergencies and related activities, effectiveness of activities, risk analysis with internal and external interested parties on a monthly basis. Based on these assessments, we assign scores based on quality, logistics and delivery performance. Based on the annual audit results, we identify specific actions and resolve errors using the 8D methodology, which includes corrective and preventive actions. We also ensure compliance with quality standards by paying attention to the control of non-conforming products and traceability.

In 2023, we will launch our Responsible Purchasing and Supplier Development project.

Within the scope of our Supplier Development Program; We will identify our sustainability risks from

our suppliers and establish a development program to support our suppliers in sustainability and increase their capacity.

- By incorporating environmental, social and governance (ESG) factors into our supplier evaluation process, we will play an active role in the assessment of sustainability performance and drive supplier performance to improve in this area.
- We will ensure development together with our suppliers with the perspective of moving towards common goals together.

With this project, we aim to improve the sustainability performance of our supply chain and create a sustainable business model by sharing ethical, environmental, and social responsibility awareness with all our suppliers.



# PLANET MATTERS



*Slowing down the impacts of the climate crisis, adapting to changing climate conditions and promoting the sustainable use of natural resources is a worthy goal for the Earth. Therefore, we say “Planet Matters” and believe in the importance of acting quickly on this issue. We are committed to sustainability and environmental protection and move forward with the mission of leaving a healthy and livable world to future generations.*

We recognize that we have a huge responsibility to tackle the climate crisis and protect the environment. We focus on all our value chains to combat climate change risks that could threaten the continuity of our production and operations. We promote the sustainable use of natural resources and take various measures to minimize our environmental impact.

In line with our sustainability goals, we take decisive steps such as increasing energy efficiency, reducing our carbon footprint and waste, managing water resources effectively and protecting fresh water resources.

Within the scope of Norm Holding Code of Ethics, Emissions, Water Use, Waste Management and Recycling, Chemical and Hazardous Substance Management, Compliance with Legal Requirements, Use of Resources were determined under the heading of Environment.



We made significant investments in 2022 to fulfill our responsibility to the environment and combat climate change. We invested a total of 4 million euros in “production track renewal”, “energy efficiency” and “renewable energy”. Thanks to investments in solar power plants, we generated more than 3 Million KWH of renewable energy in 2022. Our company has an installed capacity of 3.9 MW SPP in Izmir and Salihli and we are planning to invest in 30.6 MW SPP and 7 MW WPP.

We also perform effective energy efficiency work, ensuring that a total area of 55,000 m2 is heated by recycling waste heat and heat from the heat treatment line. We intend to reduce emissions and fossil fuel use by monitoring the carbon footprint and developing an energy-efficiency-based decarbonization map.

With all of these efforts, we focus on



# Planet Matters

ecologically responsible methods, aiming for a “Climate Neutral” future and striving to meet our sustainability goals.

We have taken significant environmental and sustainability efforts, focusing on an effective management system in these areas. Under the Management Systems and Sustainability Directorate, we coordinate crucial areas such as Environment, OHS (Occupational Health and Safety), and QMS (Quality Management System) and ensure compliance in all companies. Thus, we manage environmental activities in a centralized manner and all processes within the company in integrity and in accordance with sustainability principles. In this process, we follow environmental legislation in cooperation with three environmental experts and a consultancy firm with the goal of compliance with local legislation and zero fines.

- We conduct regular internal audits to determine compliance with legal

regulations in all factories.

- We completed legal processes such as production factories within the Holding, environmental impact assessment (EIA) applications, waste declarations and recovery participation share (GEKAP) notifications on time. In 2022, we did not receive any penalty.
- We completed the work to meet the requirements of the regulation on zero waste implementation and our employees received training on zero waste on the online training platform.
- We have made applications within the scope of EIA processes for new investments and the relevant audits have been completed. The EIA process for Solar Power Plant (SPP) field investments continues.
- In facilities subject to environmental permits, emission analysis reports showed that parameters such as CO, SO<sub>2</sub>, NO<sub>x</sub>, TOC, VOC were below emission legal limits.

*As part of the fight against the climate crisis, we aim to reduce our Scope 1 and Scope 2 emissions by 50% in 2030 and become “net zero” in 2050, in line with the EU Green Deal.*

- We aim to extend ISO 14001 and ISO 50001 management systems to all companies. We are working on energy saving, waste minimization and reducing carbon footprint.
- NormCoatingIzmir facilities were certified in 2022 and roadmaps for certification processes for other companies in 2023 have been determined.

In 2022, we do not have any penalties for non-compliance with environmental legislation.

Mitigating and adapting to climate change are among the main challenges of the 21st century. Our entire energy use and reliance on fossil fuels are at the heart of these concerns. To be successful in limiting global warming, the world needs to use energy efficiently and at the same time set a roadmap for the transformation needed to move towards clean energy sources for movement, heating, and cooling.

The European Green Deal emphasizes that further decarbonization of the energy system is critical to achieving the 2030 and 2050 climate targets. The European Green Deal, the political response to the climate crisis, makes it imperative for the region and EU trading partners to take action for our planet.

We started our first carbon footprint measurement studies by taking 2021 as the base year and we will continue to calculate our greenhouse gas emissions every year. We measure our carbon footprint at 25 campuses (21 in Turkey and 4 abroad) and 13 companies.

As a result of our carbon footprint measurement studies, we calculated our Scope 1 and 2 emissions for 2022 and determined our environmental impact on the basis of emissions within the reporting period. “As part of the fight against the climate crisis, we aim to reduce our Scope 1 and Scope 2 emissions by 50% in 2030 and

become “net zero” in 2050, in line with the EU Green Deal.”

We have taken digitalization steps to effectively manage internal audit processes and we conduct audits with the opportunity of automatic reporting at specified periods. This makes audits easier and faster and provides flexibility such as telephone reporting.

In 2023, we aim to extend audit processes to other units. Thus, we aim to create an effective internal audit culture throughout the entire company and to implement audit processes in a transparent and reliable manner. The effectiveness and continuity of management systems are regularly audited and assured by independent organizations. These internationally accredited organizations verify the compliance of our holding's management systems with international standards and make recommendations for continuous improvement.

With our robust approach to internal audits and management systems, we ensure that our operations are managed in a more transparent, reliable, and sustainable manner. We prevent potential risks in business processes and find the opportunity to take steps towards the future with a stronger foundation.

In 2022, audits conducted within the scope of ISO 14001, ISO 45001 and ISO 50001 standards

were successfully completed at Norm Coating and Norm Fasteners Bolts plants and no non-conformities were detected.

Energy consumption information is recorded in accordance with local legislation and managed by personnel with energy manager certificates. Aiming to increase the number of energy managers working in companies, we organized training sessions and hired three new employees with energy manager

certificates.

We improved the wastewater treatment system and the good practices in the corporate memory were shared more widely. New DAF (Dissolved Air Flotation) facilities were commissioned and the wastewater treatment plant was revised at Norm Coating Izmir facility.



# Achievements



With the “Planet Matters” approach, we care about combating the climate crisis to reduce our environmental impact and direct all our activities in this direction. Increasing energy efficiency and effectively utilizing renewable energy resources form the basis of our environmental sustainability goals.

We take measures to save energy, optimize energy use in our production processes and facilities, and produce more with less energy.

Thanks to the natural lighting system put into operation in our companies, daylight and ambient lighting were made possible, and carbon emissions from lighting were prevented.

We aim to minimize the use of natural resources by creating road maps on a business unit basis. Using the energy consumption data we obtain from the machines, we aim to make the right improvements to save energy. We reduce our dependence on fossil fuels

by focusing on the use of renewable energy sources and aim to reduce our carbon footprint by increasing the use of clean energy sources such as solar power plants and wind energy.

More than 3 Million KWH of renewable energy was generated in 2022 through investments in solar power plants. There is currently 3.9 MW SPP installed capacity in Izmir and Salihli. For 2023, we have planned to invest in 30.6 MW SPP and 7 MW WPP.

- Norm Fasteners Nuts business unit covered the average 17% energy consumption of its production facilities in 2022 with the SPP projects it realized.

We install emission control systems and conduct regular emission measurements to reduce greenhouse gas emissions.

Facilities that are subject to environmental permits on emissions from our factories, all values measured for parameters such



# Energy and Emissions Management

as "CO, SO2, NOx, TOC, VOC" are below the emission legal limits according to the emission analysis reports conducted by accredited laboratories within the periods in accordance with the legislation.

In order to reduce the carbon footprint in the automotive industry, we are working on lightweight fasteners in line with the increasing trends of electrification and vehicle lightweighting. We support ESG efforts by extending the range of our patented product "Hexlight" vehicles to contribute to "less carbon emissions".

We follow environmentally-friendly technologies and innovations and effectively implement environmental management systems. We organize training and awareness programs to ensure that all our employees act with environmental awareness.

Norm Fasteners Bolts İzmir preferred

hybrid systems in the heat treatment furnaces newly purchased in 2022 and reduced natural gas consumption per ton and electricity consumption by giving importance to automation works. Optimized parameters with automatic recipe selections in the surface treatment plant. Thanks to this optimization, an annual saving of approximately 96,000 kWh was projected.



### Natural Gas Consumption (MWh)

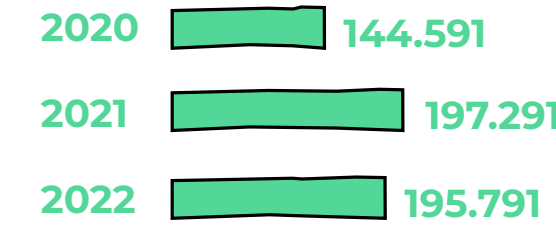

### Electricity Consumption (MWh)

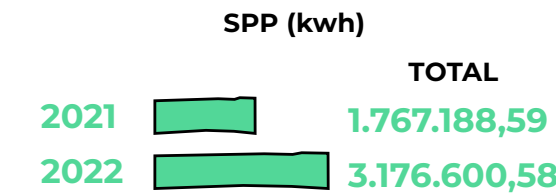
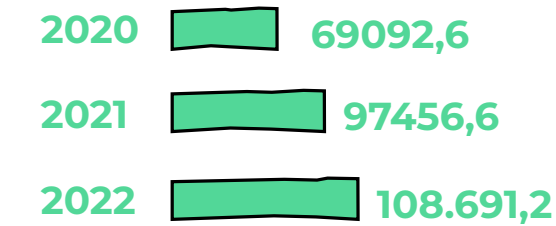

### Greenhouse Gas Emissions (CO<sub>2</sub>e/ton production)

	Scope 1		Scope 2	
	2021	2022	2021	2022
<b>Total (domestic)</b>	<b>37.708,23</b>	<b>38.281,92</b>	<b>41.086,64</b>	<b>47.144,84</b>

Carbon Intensity (scope 1&2 tons CO <sub>2</sub> e /ton production)	2021	2022
Norm Fasteners Bolts	0,45	0,46
Norm Fasteners Screws	0,53	0,61
Norm Fasteners Nuts	0,32	0,32
Norm Coating	0,06	0,07

# Water and Waste Management

By striving for the protection of water resources and sustainable water management, we are committed to our mission of protecting natural resources and leaving a healthy environment for future generations.

We strive to reduce water consumption by using water-saving technologies in our operations, and encourage the recycling and reuse of water.

In heat treatment processes with high water consumption, we conduct solution-oriented studies, research innovative technologies and identify appropriate solutions.

At the Izmir Bolt Factory, we converted the water cooling systems used in heat treatment furnaces to air-cooled systems, thereby significantly reducing water consumption. In order to improve heat treatment wastewater management in our plant, we achieved 99% improvement in the

oily water treatment system formed in the washing pools with the revision of dissolved air flotation. In this process, we searched for environmentally friendly alternative solutions for the water used for cooling in the furnaces and eliminated the use of chemicals. At Norm Nuts, we supported environmental awareness by releasing the sulfuric acid we use in surface treatment processes to the OSB line under conditions that will not harm the environment.

Norm Fasteners Bolts-Screw has started to convert heat treatment furnace water cooling systems to air-cooled systems to reduce water consumption.

We gave importance to the improvement of the wastewater treatment system and disseminated the good practice examples in the corporate memory in this field. In 2022, we increased our efforts in the field of water management, commissioned 2 new DAF (Dissolved Air Flotation) plants and carried out wastewater treatment plant

renovation works at the “Norm Coating izmir” facility in the same period. We encourage best practices in water use by raising awareness and training our employees on water conservation.

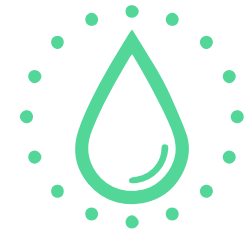

Water Consumption (m³)

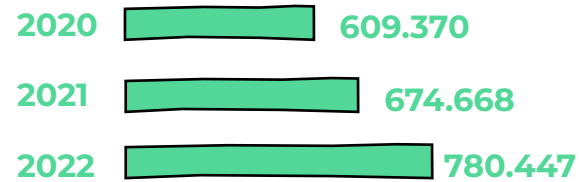

Amount of Waste Water (m³)

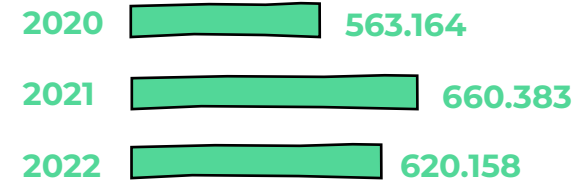

We strive to contribute to waste management and the circular economy and work on practices supporting reduction and reuse in all our operations.

We have completed various works in our facilities by fulfilling the necessary regulatory requirements within the scope of Zero Waste implementation. We were entitled to receive Zero Waste certificate in Norm Fasteners Bolts Izmir, Norm Fasteners Nuts Izmir, Norm Coating Izmir, Norm Fasteners Bolts Salihli, Norm Fasteners Nuts Salihli ve Norm Coating Salihli facilities. We carried out efforts to raise awareness of all employees on zero waste through training sessions assigned from the online training platform.

Internal audits, which are repeated every year through a consultant company to determine compliance with the legislation in all factories, were also carried out in 2022. In our production facilities, we regularly make waste declarations and Recycling Contribution Fee (GEKAP) notifications

within the legal deadlines in accordance with local regulations. We monitor the environmental impact of our waste and fulfill our responsibilities.

The modernization work carried out with sandblasting surface cleaning technique at Norm Fasteners Nuts, Izmir plant aims to significantly reduce the amount of chemical waste. Thanks to this environmental approach, we aim to contribute to the conservation of natural resources by minimizing negative impacts on the environment. We planned to complete the installation of the facility in the last quarter of 2023.

On the other hand, Norm Fasteners Romania has implemented various waste management procedures, recycling system and waste reduction in cooperation with Financiar Reciclyng company in the field of environmental sustainability.

During the reporting period, our total non-hazardous waste and hazardous waste

*6 of our facilities were entitled to receive a Zero Waste certificate.*

Waste Amount (tons)

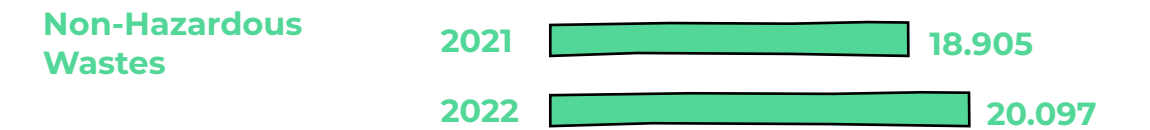

amounted to 1,368 tons and 20,097 tons, respectively.

We attach great importance to recycling waste such as paper-cardboard, metal

chips and wooden pallets in our facilities. We raise awareness and organize training sessions for our employees on waste management.

# TECHNOLOGY MATTERS



*We say Technology Matters in order to combat today's environmental and social problems, turn risks into opportunities, and create the ideal conditions for the business world of the future, and we derive our strength from research, development, and innovation.*

With our understanding of “Technology Matters,” we draw strength from innovations and digitalization to respond to global changes and meet our customers’ demands and needs. We aim to be a facilitator of the transition to a low carbon economy and to align digitalization with the global market by continuously improving our technology.

With our technology-oriented approach and digital transformation, we are moving towards the vision of becoming one of the key actors in the transition to the low-carbon economy of the future by offering more competitive, sustainable and environmentally-friendly solutions.

To achieve our goals, we attach great importance to our R&D and innovation projects and support university-industry collaborations.

We achieved significant gains by transferring repetitive and low value-added jobs to the RPA robot Normie with automation technology. In 2021, Normie gained 3,500 hours of additional labor per month and increased this figure to 6,500 hours per month in 2022, increasing the company’s productivity. This automation solution also contributed to a 60% reduction in costs.

Launched in 2021 as a pilot project, the “Paperless Factory Project” entered the dissemination phase in 2022, and all forms required to maintain production were transferred to digital platforms. This system, implemented via tablets, provides instant access to engineering and production data, productivity details, maintenance requests and the QDMS document and suggestion system.

In 2022, the “Data Collection Study”,

another important pillar of the digital transformation project, was commissioned on selected machines. Parameters that are important for each stage of production were identified and PLC and sensor infrastructure works were completed as a pilot application in order to collect these parameters as data. Norm Fasteners Bolts-Screws aims to continue to increase efficiency in production activities by completing the “Data Collection Study” project in 2023.

In 2022, we allocated a budget of approximately 113 million TL for our R&D and Digitalization activities. This corresponds to 25% of our turnover. The 2022 budget increased by approximately 303.57% compared to the 2021 budget. With our competent teams of 164 people working in our R&D and digitalization departments, we continue our efforts to move our business forward every day.

*We increased the number of employees in R&D, Innovation and Digitalization departments by 45% in 2022 compared to the previous year.*

*Normie increased our efficiency and reduced our costs.*

*We allocated 25% of our turnover to the R&D and Digitalization budget.*

# Technology Matters



Number of Employees in R&D, Innovation, Digitalization Departments

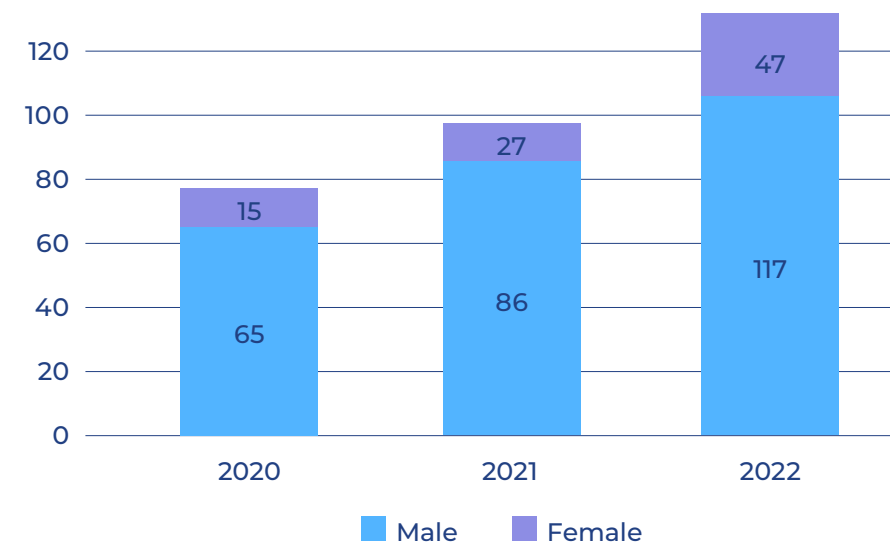

Total Budget Allocated for R&D, Innovation and Digitalization (TL)

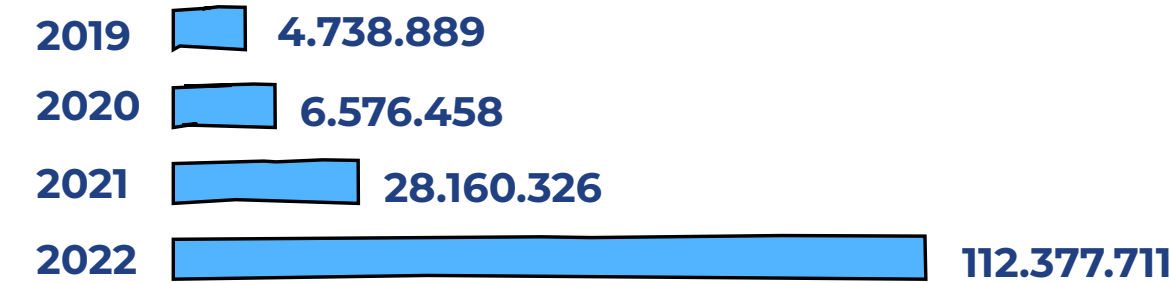

# R&D and Innovation

We focus our R&D and innovation efforts on developing high value-added products with patent and utility model potential. We set our strategic goals by taking into account factors such as customer needs, market trends, the future of the sector and technological developments. Thus, we attach great importance to R&D and innovation in order to provide better service to our customers, to be in a leading position in our sector and to build a sustainable future.

We establish collaborations with national and international universities, R&D and design centers, research institutions and companies to continuously improve our scientific and technological know-how.

The amount of calculable earnings we obtained in 2022 from innovative products developed by our R&D and Design Centers in the last four years was 80,063,763 TL in Turkey and 67,938,518 TL abroad. Since the

time we received the title of R&D and Design Center, the amount of cumulative earnings from product development and process improvement projects that we have been able to calculate amounted to 222,695,358 TL in 2022, an increase of approximately 255% compared to the previous year. In 2023, we aim for cumulative calculable earnings from product development and process improvement projects to exceed TL 250 million.

We continue our efforts to keep pace with changes and draw our strength from research, development, and innovation. By continuously increasing our investments in our R&D and design centers, we are moving forward with the goal of having a strong position in R&D and innovation. The R&D units in our enterprises work to develop innovative technologies and improve existing products and processes.

*Our 5 Patent Applications was Registered in 2022!*

**Turkey's 203rd company with the highest R&D investments**

Continuing its R&D investments without slowing down in 2022, Norm Fasteners develops alternative designs for the most important technological trends of the fastener industry and increases its competitive power day by day. Consisting of researchers and technicians from different disciplines, experts in their fields, engineers, and basic sciences graduates, most of whom hold PhD and master's degrees, our R&D Center carries

out projects in many different fields and develops many innovative solutions thanks to its strong R&D infrastructure.

Norm Fasteners also attached importance to R&D studies in 2022 in line with sectoral expectations and needs and carried out weight reduction studies. As a result of these efforts, national patent applications were filed for three products developed under the HexLight® brand and these patents were registered in 2022.

# R&D and Innovation

## Our R&D Projects for 2022

Project Name	The global trends, issues, and global goals to which we respond	Project Detail
Development of a Weight Reduced and Unidirectional (Non-Dissolvable) Fastener to be Used in Low Emission and Electric Vehicle Production	Weight reduction, carbon emission reduction efforts.	Within the scope of the project, we developed a one-way (non-dissolvable) lightweight fastener for use in electric vehicles and atmospheric vehicles aiming to reduce carbon emissions.
Design of Hold&Drive Bolt with Reduced Weight to Lighten Bolts with High Metric Diameter Used in Automotive Industry at Points with Assembly Difficulties and to Increase Occupational Safety	Increasing occupational safety in assembly operations, weight reduction efforts.	Within the scope of the project, we designed a bolt that can be assembled with the Hold&Drive method, which has a unique head form with reduced weight and can provide advantages in terms of occupational safety, in two different metric diameters, and dynamically monitored its performance on the production line.
Investigation of the Effect of Pass Number on Surface Quality in Wire Erosion Cutting of WC-Co Materials	Optimization of process parameters, increasing process efficiency, minimizing waste materials.	During the wire erosion machining of the WC-Co material studied within the scope of the project, we have determined appropriate cutting strategies that will ensure the preservation of surface quality and increase mold production efficiency - indirectly bolt production efficiency - and implemented them in production.
Increasing the efficiency of the plastering knives used in Hexlight and Hexagonal H&D product items	Increasing component efficiency, minimizing waste materials.	Within the scope of the project, we aimed to increase the efficiency of the plastering blades within the company by optimizing parameters such as material, coating, hardness, and production method for all plastering blades, focusing on blades in certain product groups.
15.9 and higher ultra-high strength fastener production	Weight reduction, carbon emission reduction efforts.	Within the scope of the project, we aimed to obtain 15.9 quality bolts for the substitution of high metric bolts preferred in the automotive industry with bolts with lower metrics and higher strength class.
Determination of Goodman-Haigh Diagrams of Various WC/Co Mold Materials at Different R Values	Material optimization, saving materials that may cause supply problems.	Within the scope of the project, we have created Goodman-Haigh diagrams for mold life predictions of WC-Co materials used in cold forging dies under different stress amplitudes. We aimed to make optimization studies on mold materials with the inferences made on the diagrams and to provide the opportunity to determine more efficient boundary conditions in simulations.

### We Developed a Mobile Application for Fastener Identification Based on Image Processing and Artificial Intelligence

Norm Fasteners R&D Center, which adopts developing projects that keep pace with the requirements of the age as a basic principle, has developed a mobile application that estimates the standard according to which bolts are produced using a mobile phone camera. The app uses image processing and artificial intelligence tools to predict standards based on snapshots taken from different angles.

Norm Fasteners R&D Center, which was awarded the first prize at İZTEK R&D and Technology Awards, received the Hewlett Packard Enterprise Achievement Category special award in the final of the TÜSİAD SD2 Program, in which it participated within the scope of the project it developed together with Kalybe.AI.

### HexLight® - Weight Reduced Fastener



Norm Fasteners continued its weight reduction studies in 2022 within the scope of R&D activities carried out in line with sectoral expectations and needs. In this context, national patent applications for 3 products developed under the HexLight® brand were registered in 2022. The Italian patent application for HexLight® was granted in 2021 and the German patent application process is ongoing.

Within the scope of the commercialization studies for HexLight®, negotiations were started with one of the automotive companies in Turkey at the beginning of 2022. HexLight® bolts with a total of 8 different codes as M16 and M18, produced within the scope of the project, successfully completed internal tests and vehicle field tests. License negotiations are underway for HexLight® products to be used in all factories globally. Under the license agreement, production authorization is granted for different manufacturers to produce HexLight®.

### Ultra-High Strength Fastener Production

12.9, which is the highest fastener strength class defined by ISO 898-1, is seen as an area open to development considering today's industry needs and expectations. As a result of the R&D studies carried out in this context, 14.8 and 14.9 production recipes were created, and prototype

production of fasteners with 16.9 and 17.9 strength classes was realized. Within the scope of the studies in which different materials and heat treatment methods were tested, fasteners with the targeted ultra-high strength class were obtained with high toughness values.

### Stainless Steel Bolt Production Trials in Full Swing

The rise of electric vehicles in the industry, the need for structures to be used in harsh corrosive environments and the needs of the sector for stainless steel fasteners are increasing day by day. Norm Fasteners R&D Center continued its work in 2022 without slowing down in line with this ever-increasing demand of the sector for stainless steel fasteners. By following new materials and technological developments, A2-70 quality hexagon and imbus bolts were successfully tested. With the knowledge and experience gained from the trials, A2-

*Standard prediction with mobile phone camera*

# R&D and Innovation

80 trials were initiated. Work continues to include stainless steel fasteners produced by cold forming method in the product portfolio. Norm Fasteners R&D Center aims to reduce dependence on foreign markets by meeting the needs and expectations of the country and to contribute to the national economy by offering competitive products to the foreign market thanks to its knowledge and experience in stainless steels.

## Trilobular Self-Tapping Bolt with Tapered Shaft Angle (Taper Trilobular) Product Group

With the increasing number of studies on electric vehicles in the automotive sector, the use of self-tapping bolts, which are among the preferred fasteners due to their properties, is becoming widespread. In this context, Norm Fasteners made sample production of special taper trilobular fasteners with tapered shank

angle upon the request of the OEM companies it supplies.

## TEYDEB 1509 - EUREKA SMART International Project Works Reached the Final Stage

Within the scope of the international EUREKA SMART project, which was launched in 2018 with its Spanish and Swedish partners, Norm Fasteners continued its production trials throughout 2022 in line with its tasks in the work packages. Within the scope of the project, a liquid nitrogen feeding system was installed on the CNC lathe and WC-Co and 1.3343 steel materials were machined with inserts, resulting in an increase in cutting tool life, improvement in workpiece surface roughness values, shortening of machining times and an increase in production efficiency in general. In addition, unlike conventional coolants, liquid nitrogen does not require

any recycling or disposal, making it more sustainable.

## TUBITAK 1505 Project was completed

TÜBİTAK 1505 is a project that aims to contribute to the commercialization of knowledge and technology in universities/public research centers and institutes by transforming them into products or processes in line with the needs of SMEs or large-scale organizations and transferring them to industry. Within the scope of this project, it was aimed to develop an abrasive paste to increase efficiency in final surface treatment by eliminating grinding and polishing processes in mold production and using AFM (Abrasive Flow Machining). In 2022, extrusion tests and field trials were conducted for molds produced using the improved paste, process parameters were optimized and the project was completed. As a result of the project, suitable abrasive types

for mold materials with different WC-Co ratios were determined, as well as suitable abrasive fluid processing parameters for targeted surface roughness values. The final presentation of the study carried out jointly with Prof. Dr. Ömer Eyercioğlu and Assoc. Prof. Dr. Kürşat Göv at Gaziantep University was made and the TÜBİTAK 1505 project was completed.

## A Leading Automotive Company in Turkey Preferred NORMSELF™

# NORMSELF™

Under the leadership of Norm Fasteners R&D and Engineering teams, one of Turkey's leading automotive companies took an important step to prevent possible assembly problems by starting to use the NORMSELF™ product, for which a patent application was filed in 2022,

*The goal of reducing dependence on foreign countries with stainless steel*

in 22 different codes. Norm Fasteners is proud of the preference of its innovative products and aims to contribute to other projects with reputable automotive manufacturers in Turkey and abroad with its specially designed products.

## Norm Fasteners R&D Center Receives Second Award at 2022 RDCONF R&D and Innovation Awards

Norm Fasteners R&D Center, which participated in the "RDConf 2022 - International Conference on Design, Research and Development" conference held on 14 - 16 December 2022 with the support of ARGEMİP, was awarded the second prize in the "Steel Structure and Production" sector within the scope of "R&D and Innovation Awards" with its "Realization of Mechanical Strength and Torqueing Studies for Weight Reduction in Norm One Way Patented Product".

We prioritize R&D and innovation projects in line with our goals for the future. In 2030, we plan to direct 30% of our expenditures to sustainable product projects.

We aim to increase the number of intellectual and industrial rights applications to 7 and the number of scientific publications to 20 in 2025 in order to further advance in the field of innovation and increase the competitiveness of our company.

With our R&D and innovation investments, we aim to bring innovative and sustainable products to customers from different sectors. Thanks to our strong R&D and innovation infrastructure, we respond to our customers' special product demands and produce value-added solutions. For example, the project to develop the Thin Walled and Flanged Weight Reduced Bushing product aims

to reduce CO2 emissions by reducing import dependency in the automotive sector.



# Intellectual and Industrial Property Rights Activities

## Intellectual and Industrial Property Rights (IPR) Policy

To ensure the sustainable increase of its intellectual capital, one of the most important sources of its competitive power in the sector, while moving forward in line with its short/medium/long-term strategic goals, In order to create an "Intellectual and Industrial Property Rights Culture" adopted within the Holding, we established a detailed and comprehensive Intellectual and Industrial Property Rights Policy in the operating period of 2022. Thus, we aimed to ensure the continuity of innovations realized through creative ideas, innovations and products created by human resources, which are the building blocks of intellectual capital

The scope of the IPR Policy includes;

- If any new idea product constitutes an intellectual and/or industrial property right, the principles regarding the protection of these rights and the rights and obligations related to them,

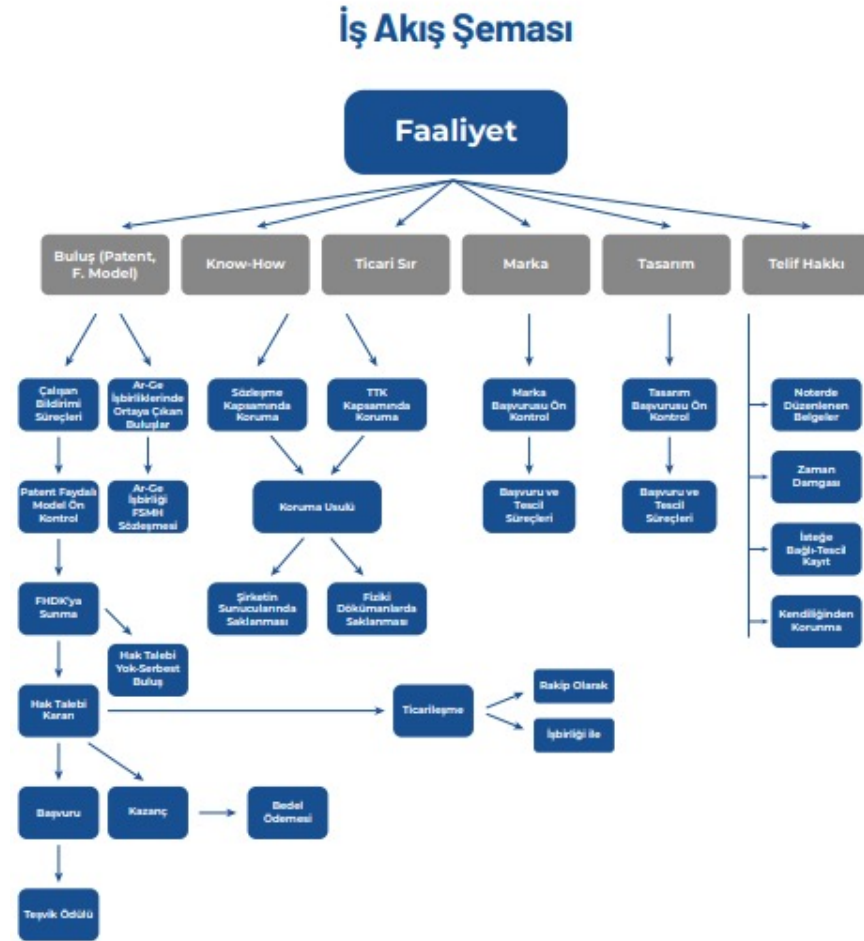

- Procedures and principles to ensure that the obligations defined for IPR are fulfilled in accordance with current laws and regulations and that the relevant processes are managed,
- Details of legal and operational processes related to IPR,
- Compensation and incentive systems that encourage employees to produce innovative solutions in accordance with laws and regulations,
- Rights and obligations regarding the identification of inventions and other intellectual products resulting from collaborations with real and legal persons, protection as IPR and management of the processes,
- Issues related to the fair sharing of the economic benefits to be derived from the commercialization of IPR between the parties.

Working in conjunction with each other to systematically implement the processes described in the IPR Policy in

all our companies;

- An Intellectual and Industrial Property Rights Unit (IPRU), consisting of one member from each of the companies within the Holding where IPR activities are carried out, was established to carry out operational processes within the scope of IPR,
- and an Intellectual and Industrial Property Rights Evaluation Committee (IPREC), consisting of executives at the Senior Management level, to make critical decisions regarding the IPR portfolio in line with the work of the IPRU and the company's strategies.

## IPR Policy Internalization Efforts within the Holding

After the preparation of the IPR Policy, meetings were organized with the Holding's company employees on issues such as the content, purpose, and implementation of the policy, IPR Strategies of the companies, patent research, utilization of patents in product

designs, invention notification processes, and internalization activities were carried out. Meetings will continue throughout 2023.

## 3 New Patent Applications Added to Our IPR Patent Portfolio in 2022 Activity Year!

### NORMSELFTM Patent Application

**NORMSELF™**

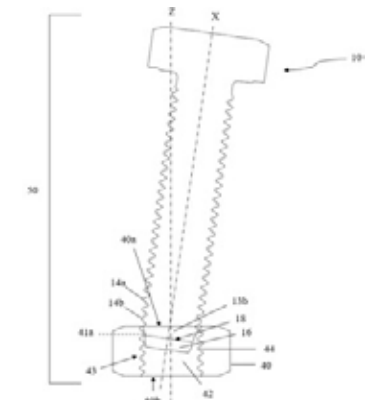

A

our NORMSELF product, which has a special end form design that prevents thread wrapping and assembly problems caused by thread wrapping when fasteners are not in axial alignment. Our patent application is under examination.

## Patent Application for a Fastener Recognition System and Method

A software patent application was filed for the first time at the R&D Center, where the "Mobile Application for Image Processing and Artificial Intelligence Based Fastener Identification" was announced, which won the Hewlett Packard Enterprise

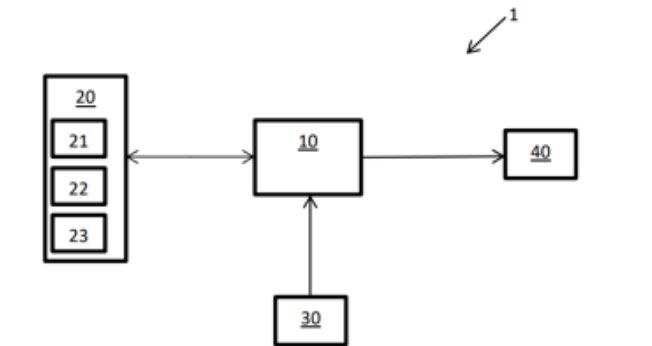

patent application was filed describing

# Intellectual and Industrial Property Rights Activities

Achievement Category special award and the first prize at İZTEK R&D and Technology Awards at the finals of TÜSİAD SD2 Program (Application. No: 2022/021731).

## Patent Application for Self-Threading Externally Threaded Fastener

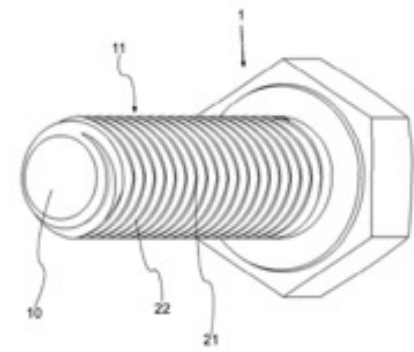

In the production of fasteners with lobular shafts, a patent application has been filed describing an externally threaded fastener with a quadruple lobular shaft, developed to eliminate the

need for specially designed combs in order to create the desired quality of the thread form on the shaft (Application No: 2022/021646).

## Norm Additive - Diesel Burner project December 15, 2022

The prototype products were sent to the main customer and the first working prototypes were completed. In this way, assembly problems or problems during operation were identified and design revisions were made.

The diesel burner body part, which is geometrically impossible to produce with conventional production methods, was produced by additive manufacturing. Thanks to this method, the complex geometry of the part could be successfully reproduced. After the production process, machining operations were carried out on the parts and they were brought to assembly precision.

In this process, the variability in structural occupancy rates between the additive manufacturing techniques used by different brands emerged as an important factor. This variability is something to consider as it can have an impact on the performance and durability of parts.

Within the scope of the project, Norm Additive prioritized this and similar projects. Based on the successes and feedback, the details that needed attention were noted. These notes will be used in future projects to achieve better results and make the process more efficient. Norm Additive aims to move forward by focusing on such projects with advanced technology and innovative solutions.

We take the privacy of our customers very seriously and strictly enforce our privacy policies. We cannot share customer names due to project confidentiality.

# Digitalization



## Norm Digital, More Digital!

With the importance we attach to the digital transformation process, we continue our efforts to implement new applications and projects, adapting to the requirements of the age and increasing efficiency.

We know that digital transformation is inevitable in order to maintain our competitive edge and support our strategic decisions with a strong infrastructure. Together with our employees, we are building SAP projects that will build our future and transform all processes included in the strategy map.

We achieved great success by simplifying our information technology infrastructure with S/4HANA, SuccessFactors, Sales and Commerce Cloud, it.mdsADD solutions. Thanks to this integration, we accelerated processes and increased overall efficiency in operations. With instant reporting and analysis in financial processes, we created

effective decision-making mechanisms and provided more effective guidance to operations.

In 2017, we decided to invest in SAP within the framework of the technological infrastructure, tools and digital transformation plan we set for the next 10 years, and we switched all group companies to SAP implementation.

Our digital transformation project brought the IBP project, the first of its kind in Turkey, to life. In this way, we have created an integrated management and monitoring platform with a flawless supply chain management approach in our production and sales companies located in Saliqli, Izmir, Germany, and France. Thanks to this platform, we have made traditional sales and operations processes as well as planning and financial management processes controllable end-to-end from a

single center.

Our digital transformation project went live in as little as one year and the results have been quite impressive. We have created effective decision-making mechanisms regarding operations by providing real-time reporting and analysis within Norm Holding and Norm Bolts. We realized data flow through a centralized system in storage and supply management processes. With it.MDS & PLM integration, we automated all processes starting from the design phase of the products. We designed the process of master data creation in accordance with the structure of our holding and reduced the time to create products in multiple profiles to 4-10 seconds. In this way, we achieved a faster and more efficient production process.

**We aim to be a customer-oriented company with our digital vision and leadership role, and we continued our digital transformation in 2022.**

We are implementing new applications and projects within the scope of digital transformation. We include digitalization in every process from production to packaging, and we incorporate the RPA system into our production lines and offices with our digital colleague Normie. We continued our digital transformation journey in 2022 without slowing down in order to facilitate our business processes.

**By transforming our business processes with digital technologies, we are fundamentally shaping the way we create value.**

We have realized the importance of digitalization in order to take fast and

# Digitalization

*Our information technology infrastructure has become simpler, our speed and efficiency have increased.*

accurate actions, and we monitor and transform our operations to meet ever-changing demands. Investments in new technologies and digitalization increase automation, ensuring efficiency and safety. The Digital Transformation Committee established within our organization aims to improve efficiency, customer value, risk management and new revenue generation opportunities by monitoring the application of digitalization to processes, products, and assets in the sectors in which the company operates. In line with the targets set by the Executive Board, the Committee completes analyses and evaluations on topics such as digital factory, energy monitoring, digitalization of processes, digital literacy, simplification of office processes and data management, and submits written opinions to the Executive Board.

Our focus areas include shortening product lifecycle time, reducing manpower utilization, lowering production cost, and creating new technology. Within this framework, we evaluate the efficiency of digitalization projects and then initiate them. We understand the need of digitalization in order to differentiate ourselves from our competitors and to take quick and accurate measures that will allow us to satisfy ever-changing demands. We continuously monitor and transform our activities in line with the trends and changing behaviors driven by digitalization.

By investing in new technologies and digitalization, we significantly increase the level of efficiency and security by increasing automation in business processes.



# Projects

**Digital Factory:** By the end of 2022, the Cold Forming Process had been successfully rolled out in 4 production factories. In addition, conceptual studies were initiated for the Heat Treatment Process.

- Target of 35% reduction in paper use in Norm Holding subsidiaries

**Lion Project - ibaPDA Data Collection and Analysis**

- Tracking production data on a single digital platform
- Matching process parameters with production data
- Creation of institutional memory
  - Izmir Bolt is the Designated Pilot Region

**Digitalization of Supply Chain Processes** Priority projects were created in 6 main processes to design a digital Supply Chain that is technology-enabled, end-to-end traceable and managed with real-time data.

In order to improve customer delivery performances, the realization rate in the OEM category was 96% against our target of 90% for 2022 and we will continue with our target of 96% for 2023. In addition, in the Manual Customer category, the target for 2022 was 80%, the realization was 88%, and we set a target of 90% for 2023.

# Projects

## Increasing Digital Literacy

During the digital transformation process, we aim to increase the digital literacy level of our project managers and employees, identify the digital competencies of our employees and carry these competencies forward.

- Increasing the level of digital literacy by at least 50%
- All office employees and 90% of Field Leaders receive basic digital literacy training



- Closing 80% of the digital competence gap

In 2021, we established the Digital Transformation Committee and determined one of the working subjects of the committee as maximizing Norm Holding technology/digital transformation competencies by creating a Digital Competence Academy.

In 2021, we worked on the content of the Digital Competence Academy, conducted benchmarks, and held meetings with consultant organizations. In 2022, we launched the Revolutio'N program to support employees to acquire new skills, use them in data analysis and create dynamic and up-to-date reports. 138 employees applied for the project and Basic and Advanced Power BI Training sessions were provided in 2022. At the same time, a competition was held among the employees who received Power BI training, and the top 3 employees were

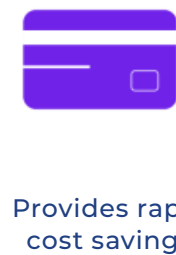

determined and rewarded. In 2023, it is aimed to continue with RPA Training Programs.

Simplifying Office Processes with Normie  
Aim of the Project:

- Improves efficiency and accuracy
- Eliminates errors and waste
- Saves time
- Saves money

- Redistributes resources
- Reveals new insights
- Reduces monotonous tasks
- Increases competitiveness

In 2021 - 2022, the workforce of 22 persons was transferred through 103 processes.

Approximately 2000 documents are archived every month and this process generates 30 hours of revenue per month. In the same way, an average of 40000 tags are ranked per month and this process generates a monthly profit of 60 hours. Through the HR Chatbot, we can ask Normie for information such as Food, Service, Leave, Payroll, Health Services through the Teams platform and get answers quickly.

## Data Management

Executive Dashboard (presents past, present, and possible predictive outcomes)  
Predictive business analytics model

## Digitalization of Procurement Processes

Priority projects were created to increase operational efficiency and process standardization, to ensure that all suppliers can be monitored through the system and to create digital integration.

## Paperless Office

With the paperless office project, we want to create a working environment where the use of paper is minimized, primarily thanks to digitalization. The main goal of the project is to form a project group consisting of representatives from the departments with the highest paper consumption, to enable these teams to perform the most paper-consuming tasks on a digital platform, and thus to reduce paper consumption.

# HUMAN LIFE MATTERS

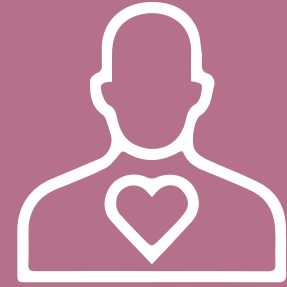

*We adopt a people-centered approach to support gender equality, increase our competitiveness by leveraging the power of diversity and inclusion, train competent employees for the sectors in which we operate and increase local employment.*

As Norm Holding, our employees are at the center of our corporate culture with our “Human Life Matters” approach. In this direction, we value our employees and strive to provide them with a good working environment for sustainable success. We conduct talent, career, and performance management processes to continuously improve our human resources.

By embracing equal opportunity, diversity, and inclusion, we treat our employees equally and always support their development, which is the basis for the realization of our strategic goals.

We aim to achieve and certify the “Zero Work Accident” target in all fields of activity. The safety and health of all our employees is among our top priorities and

we attach great importance to providing safe working environments. We minimize risks and take measures to prevent occupational accidents.

In order to support gender equality, we encourage women to participate more in business life and management by providing equal opportunities. We see diversity and inclusion as a valuable strength and focus on creating innovative solutions by bringing together employees from different cultures, ideas, and perspectives.

In order to increase our competitiveness and become a leader in the sectors in which we operate, it is of great importance to train competent and qualified employees. We offer various development programs to improve skills. While equipping existing



# Equal Opportunity and Diversity

*Our female employee rate is increasing every year*

talents with new skills, we contribute to the development of prospective talents by providing short and long-term internship opportunities. We aim to prepare our managers for the requirements of an ever-changing world and transform them into leaders who can manage change.

We prioritize local labor to increase local employment and contribute to our society. We work with local communities to create employment opportunities and support economic development.

We care about equal participation of our employees in the workforce and gender equality. We observe the principle of equality in our relations with every employee and aim to create an equal opportunity, diversity, and inclusive working environment.

We strictly adhere to the principle of non-discrimination on the basis of factors such as age, gender, race, religion, language, ethnic origin, sexual orientation, belief or disability in our recruitment and other business processes. As a member of the UN Global Compact, we act in line with our ethical principles and are committed to protecting the rights of our employees and providing a safe working environment. We aim to eliminate the difficulties that women and young people may face in their career journeys and support career development in an environment where everyone has equal rights.

- We undertake initiatives such as mentoring programs, leadership training sessions and opportunities to take responsibility in different projects to encourage women to advance in their careers. We also support the

integration of our young employees into the business world and their professional development by offering internship programs and career planning support.

As Norm Holding, we implement continuous improvement policies to respect the rights of our employees and provide a fair working environment. Our senior management and our entire company are committed to prioritizing the safety and well-being of our employees.

We organize awareness programs within the company to ensure equality, diversity, and inclusion. Through these programs, we increase our employees' experience of working with colleagues from different cultural, ethnic, and social backgrounds. We also ensure that our employees are aware of issues such as discrimination

and harassment through our policies and training sessions.

We increased the proportion of women working in managerial positions from 15.1% in 2020 to 23.2% in 2021 and increased the total number of employees in this position. In 2022, we increased this rate to 25.6%.

We have a workforce of young employees, with the ratio of Y generation employees reaching up to 80 percent and Z generation employees at 8.6 percent. As a company, we focus on continuous development to make human resources processes agile and resilient, with the understanding of "Human Life Matters". We develop practices that improve the employee experience, design processes to meet talent expectations and enable employees to add value to our company and themselves.

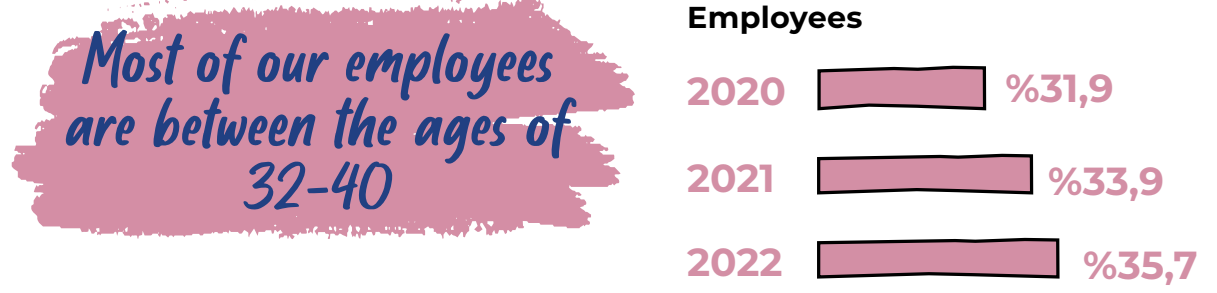

## Organizational Structure - Employee Demographics

Employee Subgroup	Woman	(%)	Male	(%)	Total
Office Worker	287	35%	527	65%	814
Field Worker	55	2%	2,967	98%	3,022
<b>Total</b>	<b>342</b>	<b>9%</b>	<b>3,494</b>	<b>91%</b>	<b>3,836</b>

Generation	Percentage
Generation X	11.0%
Generation Y	80.2%
Generation Z	8.6%
Generation BB	0.2%
<b>Total</b>	<b>100.0%</b>

Age Range	White Collar	Blue Collar	Intern	Total
18-25	82	862	22	966
26-31	263	870	1	1,134
32-40	292	870	0	1,162
41-50	138	378	0	516
51+	39	42	0	81
<b>Total</b>	<b>814</b>	<b>3,022</b>	<b>23</b>	<b>3,859</b>

# Talent and Competency Management

## Together With You

Together with all our employees, with our motto *Seninle Birlikte* (Together With You); we aim to continue to

- Make a difference for the customer,
- Believe in the power of the team,
- Prioritize diversity and inclusiveness in all its processes with the principle of fair and respectful treatment,
- Design ways of doing business in a way that adds value to society and the environment
- Maintain with our values based on continuous improvement of ourselves and our norms.

**In 2022, we restructured the Career Planning, Progression and Succession Process.**

### Career Planning, Progression and Succession Process

We develop talent management processes and the strategies for organizing this process - "identification and acquisition", "development and retention", "attention and succession" - in line with the future of the current business. In this context, we restructured the "Career Planning", "Progression and Succession Process" in 2022, as we do every year. Our Holding has adopted the principle of managing all business development processes together with our employees, and has accepted the dynamics of the individual's workforce, potential, talent, competence, and continuity as the building blocks of this togetherness.

### Potential Identification Process

In line with career planning activities, the potential of our employees is determined through objective inventories and assessment center practices. While

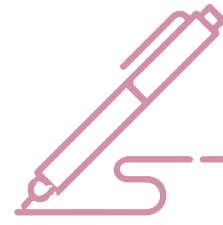

*We believe that our employees are our most important capital in achieving our future goals, and our subsidiaries invest in talent, aim for high employee engagement, and offer a development-oriented work environment.*

the strengths and development areas identified after the application are conveyed to employees through one-to-one interviews, the development actions to be followed by both parties throughout the year are also planned together. In 2022, 415 employees were involved in the potential identification process.

### Talent Management Process

Following potential identification studies, we developed the Talent Management Process to utilize our talented employees who will contribute to the successful achievement of our strategic goals. We place our employees in the "Performance-

Potential Matrix" by taking into account their performances throughout the year. We contribute to their development with various actions according to their place in the matrix.

For a sustainable organization, we identify the backups for all management roles and prepare them for their future positions. We make backup plans so as not to stop the operation in case of possible need. We objectively evaluate all of our employees with defined promotion criteria and we carry out the process transparently.

### Development Activities

We are well aware that systems and technology alone are not a means of superiority, and we attach great importance to working on employee talent development processes, which rank first in terms of importance in sectoral activities. With the development tools we offer, we aim to strengthen and develop the competencies and skills our employees need today and for the future.

### N'Academy

Launched in 2018 to continuously improve norms in line with our strategies, N'Academy continued its journey in 2022 with a focus on development. We organize various training sessions, seminars, and workshops at Norm Academy. During the period when classroom training sessions were suspended due to the pandemic, we supported the development of employees with webinars and virtual classroom training sessions.



**"ENLider Sensin" Leadership Development Program, Development Coaches, Apprentice Development Program, Power of the Field, Power of Norm, NorMentor Mentoring Program, vocational and technical training sessions.**

**Number of Participants: 3,560**

Human Resources ambassadors were created with the Development Coaches application. Development of first-line managers was ensured through the Power of the Field, Power of the Norm program.

**2022**

Total Training Hours	47959
Average Training Hours per Employee	12,51
Training Expenditures (\$)	733546

# N'Academy



## Training and Programs

### Sustainability Training Programs

In 2022, we organized online “Basic Sustainability Training Sessions” in order to contribute to sustainability goals, increase the knowledge of our employees and make them more competent in their line of business. For 2023, we have planned online awareness-raising training sessions through the online training platform and at regular intervals.

### Digitalization Strategy and Digital Literacy Training

We aimed for our managers to integrate their teams by internalizing technological transformation in a competitive environment changing with the impact of globalization.

### Revolutio’N Project Training Programs

In 2022, we provided “Basic and Advanced Power BI Training Sessions” in the project, which was implemented to support our employees to acquire new skills, use these skills in data analysis, and create dynamic

and up-to-date reports. We aimed to continue this comprehensive training process with RPA Training sessions in 2023.

### Code of Ethics Training

We provided online and face-to-face group training sessions to raise awareness of all our employees about the “Code of Ethics Procedure” and the “Ethics Line” and to ensure honest and responsible business relations that respect the organization. We have planned refresher training sessions for 2023.

### Apprenticeship Development Program

We have planned development activities to support the development of apprentices outside the MoNE courses. We have also expanded the scope to include the families of apprentice students and teachers in the program for collective development. We organized personal development training sessions, technical training sessions, seminars, project studies, technical and cultural trips for apprentice students; personal development training sessions, technical training sessions, seminars, and technical trips for teachers; awareness seminars and parent meetings for students’ families.

### Power of the Field, Power of Norm

The “Power of the Field, Power of Norm Project”, which has been implemented since 2018 with the aim of ensuring that the field manages the field and the development of first level managers,

continued in 2022. Field and team leader candidates received training sessions on Team Management, Communication and Relationship Management.

### Vocational and Technical Training

In 2022, as in previous years, we supported our employees with vocational and technical training sessions to maximize their skills in their respective fields.

### Master’s & Doctorate & Certificate Programs & Foreign Language Education

Aware of the value that individual development will add to the organization, we supported our employees’ foreign language development through master’s, doctoral or professional certificate programs.

### Leadership Styles and Employee Engagement Management

In 2021, we reviewed and strengthened our

leadership approach and leadership model with a perspective that draws its strength from the team. Norm Holding Leadership Model combined the Norm leader’s aim of being a role model by inspiring his teammates with its result-oriented and transformational structure.

### Our Leadership Model

As an organization that attaches importance to leadership development, we launched the “EN Lider Sensin Leadership Development Program” and the “NorMentor Mentorship Program”.

### EN Lider Sensin Leadership Development Program:

Launched in 2020, the program aims to strengthen the skills of managers who uphold corporate values and demonstrate effective leadership.

The new cycle of the program started at the end of 2022. First-

time managers participate in the Leadership Development Program, while managers who have previously participated in the program participate in the Strategic Leadership program.

A total of 114 managers participated in

the program.

2022 Silver Award in the Best Leadership Development Programs category at the Brandon Hall Group Human Resources Excellence Awards. The program includes various learning



methods with a hybrid education model. Methods such as in-class training sessions, one-to-one coaching interviews, group coaching, digital learning platforms, 360-degree reports and feedback interviews are used.

- Content is renewed every year in line with corporate strategies and goals.

#### Development Coaches

Development Coaching is a project realized in cooperation with Human Resources and employees who volunteer in Human Resources projects. Development Coaches, who play an active role in the preparation and follow-up of individual development plans for employees' career journeys, were selected on a voluntary basis. Development coaches, who became competent in learning and development methods through training sessions, supported their teammates in making their development plans. A 40-person team of Development Coaches and Human Resources team

completed their first semester in 2022.

The 2-session learning and development methods training sessions held in the company of a consultant company include learning, learning styles, learning tools, identifying development areas, and preparing individual development plans. After the training, workshops and shadow coaching were held.

#### NorMentor Mentoring Program:

## NORMENTOR

- The program, implemented since 2019, aims to achieve our strategies and ensure the development of our employees.
- The process is voluntary. Managers at the level of manager and above can apply to the program as mentors, while employees at the level of senior specialist and below can apply as mentees.

- A total of 31 mentors and 35 mentees took part in the program, which started in 2021 and ended in 2022.
- During the program, 245 interviews were conducted.
- Training sessions with special content were organized for mentees and mentors and interim evaluations were conducted to monitor the program.
- Program participants stated that they improved their skills in asking questions, listening effectively, and reflecting on different experiences.

#### Young Talent Acquisition Programs

Our young talent acquisition programs include "DigiConnect Online Development Program", "N'Talent, SAP Academy", high school and university, summer, and long-term internship programs. Through these programs, young talents have the opportunity to discover their potential, develop their competencies and determine their career paths in different functions of

our companies; the sustainability of human resources is aimed by bringing talents with high potential into our holding.

#### DigiConnect Online Development Program

## DigiConnect

The DigiConnect program, where young talents develop projects and generate new ideas with professionals and experience business life with online learning and development opportunities, continues in two semesters, summer, and winter, since 2020. In 2022, a total of 13 students participated in the program, which is conducted entirely online. Young talents who complete the program are prioritized in new graduate programs and open roles in Norm Holding companies.

#### N'Talent Program

Within the scope of the N'Talent Program, which was launched in 2022, young talents

who are 3rd and 4th year/graduate students are supported with project work and online /in-class development programs under the guidance of their mentors, while working part-time 2-4 days a week to experience professional life. In 2022, 10 young talents took part in the program and 3 talents who successfully completed the program joined our organization as permanent staff.

#### SAP Academy



The program, designed for university or graduate graduates aiming for a career in the SAP world, was launched in 2022 with 7 young talents. Participants worked as a team member within the scope of on-the-job training in Norm Digital SAP Module Consultancy departments for a year and continued their personal and professional development journey with mentoring

program, project experience, training sessions and visionary conversations.

#### Norm Internship Program

Within the scope of Norm Internship Program, summer and long-term internship opportunities are offered for vocational high school students and university 3rd and 4th year or graduate students. The internship programs aim for young talents to discover their interests, develop their competencies, experience project management and working life by working with expert staff in our companies in the fields they want to experience. In 2022, 29 high school students and 53 university students participated in the program. Students who successfully complete the Norm internship program are prioritized for new graduate programs and open roles in Norm Holding companies.

#### Norm Coating Academy



We established Norm Coating Academy to improve customer experience and loyalty. Through this academy, we meet all the information and training needs of customers in the field of coatings. Customers have the opportunity to participate in these training sessions as they wish, face-to-face or online.

#### Recruitment Process

In today's dynamic and competitive business environment, we aim to bring high potential and qualified professionals to the organization with new generation digital recruitment practices focused on

candidate experience.

We reviewed all recruitment systems and processes to carry out the recruitment process through end-to-end digital platforms, and prepared a new generation recruitment fiction in 2022.

With our people-oriented approach principle, we aim to provide a strong experience for all candidates and to this end, we receive feedback from candidates about recruitment processes through the "Candidate Experience Survey", which was introduced in 2022. Each stage of feedback data contributes to our innovative and effective recruitment process approach. We evaluate the results of tests and inventories specially prepared for our Holding in the light of current scientific methods in recruitment processes. The apps provide us with an objective result, from choosing the right position for the right candidate to assessing the sustainability of the selection. While existing talents are evaluated for



open positions, the selection process of the candidate and the employer gains quality with the “Steer Your Career” internal announcement system. In 2022, 38 internal advertisements were published, 24 office employees were offered career opportunities through internal rotation and were provided with the opportunity to increase their knowledge and experience.

#### Performance Management System

We know that corporate success depends on individual success, and we ensure that all our employees are included in the Performance Management System. We aim to increase individual success by evaluating the performance of our employees after the process.

We aim to evaluate the performance of our office staff in a fair, transparent, systematic, and measurable manner. Accordingly, in 2021, our employees started working with the OKR (Objectives & Key Results) methodology, which centers on continuous development.

In 2022, the Performance Management System was realized through “face-to-face or online employee-manager meetings” and “year-end performance interviews” based on the company’s strategic target schedule.

With the Performance Management System, we aimed for a collective and more agile working organization for our

field employees; we aimed for continuous improvement by strengthening the system.

In the year-end performance evaluation, we put our employees through a fair and objective filter, and we established a relationship between the Performance Management System success outputs and talent management.

In 2021, we increased the proportion of employees subjected to regular performance and career development evaluations by 19% compared to the previous year. Likewise, we achieved a 13% increase in 2022 compared to the previous year.

#### Employee Loyalty

Under the leadership of the human resources department, every two years, an independent research company conducts an “Employee Opinion Survey” on our behalf. The measured survey accelerates the employee experience to perfection and the company performance analysis process. In the measurement, our holding is evaluated by its employees on the factors of agility, talent focus, engaged leadership, commitment, and satisfaction. After reporting the survey results, which are monitored by Human Resources, to the senior management, we convey the strengths and areas open to improvement of our company to all our employees through meetings. In 2021, as a result of

the “Employee Opinion Survey” conducted in all affiliated companies, 3 companies of our holding (Norm Tooling, Norm Coating and Norm Fasteners Screws) received “Turkey’s Best Workplace Award” within the scope of “Kincentric Turkey Best Employers Program”.

In addition to the measurement work, we collect expectations and requests through focus group discussions, set goals for leaders in the performance system and include them among the prioritized tasks. Based on the survey results, we form action committees. These committees analyze the data obtained and determine the necessary actions based on employee feedback. Action committees take measures and create programs to improve working conditions, strengthen communication, develop leadership skills, and increase employee satisfaction. This process encourages employee engagement and aims to foster a more positive working environment in the workplace.

According to the results of the survey conducted in 2022, the satisfaction rate of our employees was 84% and the average loyalty score was 70%.

We prepared a procedure to guide mothers on working conditions during pregnancy, childbirth and breastfeeding, pre- and postnatal leave practices, and legal rights, and published it in 2022.

In 2022, within the scope of our sustainability efforts, we implemented a 10-day leave practice in addition to the “Legal Paternity Leave” in order to support equality of opportunity, for Norm fathers to be with their newborn children more in the first time, to take an active role in the care and development of the baby and to share the responsibility of parenthood.

Company	Satisfaction Score 2022	Loyalty Score 2022
Norm Fasteners VidaScrews	88	84
Norm Fasteners Bursa	89	50
Norm Fasteners CivataBolts izmir	70	55
Norm Coating	86	80
Norm Digital	79	59
Norm Holding	82	71
Norm NRM Engineering	90	82
Norm Fasteners CivataBolts Salihli	83	70
Norm Fasteners NutNuts	81	71
Norm Tooling	91	80
STD	86	67

# Occupational Health and Safety

*A total of 42,654 hours of training was provided.*

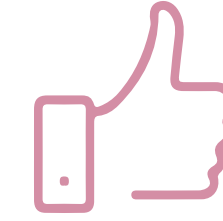

We prioritize the health and occupational safety of our employees and offer training sessions to increase their OHS awareness. We create safe working areas by conducting risk analysis in our activities and trying to reduce OHS risks. We manage our business processes effectively with OpenOHS software. We monitor occupational accidents and actions taken with the occupational accident module. Thanks to the training module, we record and report employee training sessions. We track subcontractor documents with the subcontractor module. With the health module, we manage periodic examinations and health services.

We implement OHS practices in office and production areas in accordance with the law. We guide these practices with our Occupational Health and Safety Policy. From raw material procurement to production, transportation, and other services, we provide support to create safe working environments.

We attach great importance to protecting the physical, mental, and spiritual health of employees in all business processes. This is among the highest priorities both for our business and for our most valuable stakeholders, our employees.

In order to realize our goal of zero occupational accidents, we are taking steps to make occupational health and safety a part of our corporate culture by taking occupational health and safety beyond legal limits. Prioritizing the health and safety of our employees and all our stakeholders is at the heart of our work.

In 2022, we centralized occupational health and safety activities under the Management Systems Directorate and strengthened coordination among our companies. To encourage the sharing of good practices, we started organizing cross-factory tours with the participation of occupational safety experts and supervisors. Thanks to these trips, we

identify high-risk areas and create action plans.

As part of our ISO 45001 Occupational Health and Safety Management System certification efforts, we recertified the Norm Fasteners Bolts Izmir facility and completed the certification of Norm Coating Izmir facilities. We aim to complete the certification processes in our other companies in 2023.

We meticulously analyze the situations

that pose risks in terms of Occupational Health and Safety (OHS) during our activities and take the necessary measures to minimize these risks. We assess risks and determine appropriate measures through cross factory visits with the participation of occupational safety experts and occupational safety officers. In 2022, the accident frequency rate was 2.1 with a 35 percent improvement compared to the previous year, and the accident severity rate was 41.6 percent with a 13 percent improvement compared



to the previous year (TAYSAD benchmark data was used in the calculations of these data).

In 2023, we set a target of reducing the frequency and severity of accidents by 15% for all our business units.

We are aware that the most effective way to improve Occupational Health and Safety (OHS) awareness and culture is the training sessions we provide to our employees and we aim to increase these training sessions. In this context, we provided a total of 42,654 hours of training in 2022. Of this period, 23,152 hours consisted of face-to-face training sessions and 19,502 hours of distance education. With Occupational Health and Safety Training sessions, we increased the number of training hours by 63% compared to the previous year and strengthened the knowledge level of our employees.

**In 2023, we aim to continue our work in this area by establishing an Employee Welfare and Wellbeing Program.**

Considering the hazard classes of our companies, we organize Occupational Health and Safety (OHS) board meetings in accordance with legal processes. In these meetings, we took 395 decisions in total, 73% of which were completed.

In order to ensure safer use of the machines and equipment in our factories and warehouses, we regularly carry out periodic inspections, identify improvement steps in this process and follow them systematically. In 2022, we carried out periodic controls of 2402 machines/equipment in total.

Considering factors such as the geographical location, production methods and number of employees of our enterprises, we have created plans for emergencies such as fire, earthquake, and flood. To effectively implement

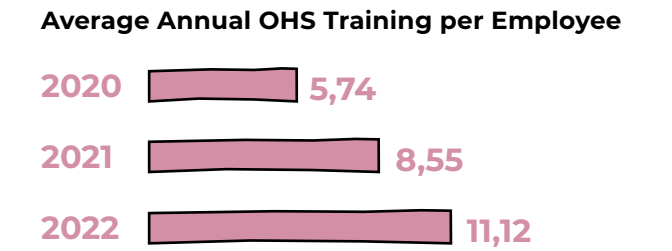
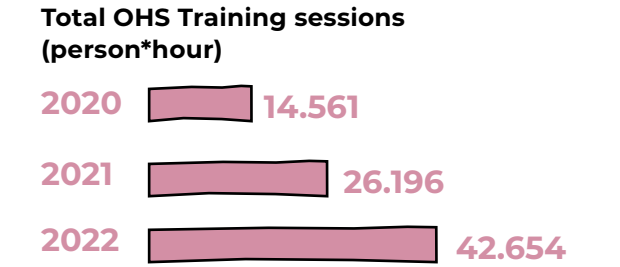
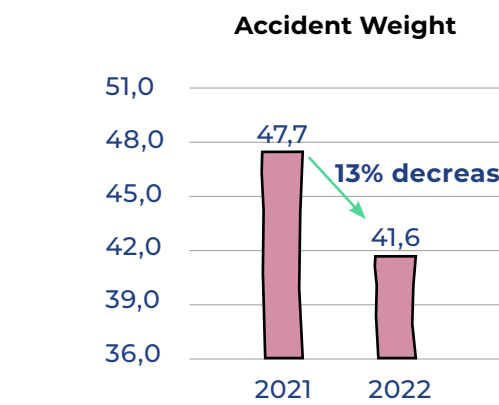
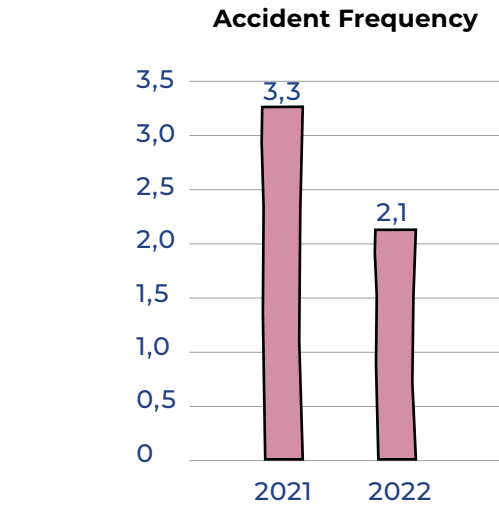

these emergency plans, we provided emergency teams with a total of 1,157 hours of training and conducted 17 emergency drills at our facilities.



# Social Activities



We aim to improve the vision of society and build a brighter future by working in the fields of quality education, culture, arts, and similar fields.

When determining our social investment strategies, we focus on common problems

that align with our values and strategy. We aim to grow the value we create through social projects in the geographies where we operate. We invest in the regions where we operate to support local socio-economic development.

## Norm Holding CSR Focus

We focus on quality education and culture and arts in our corporate responsibility projects.

### Foundations/associations through donations

- Foundation for the Evaluation of Women's Work
- Association for the Support of Contemporary Life

### Private IAOSB Nedim Uysal Vocational and Technical Anatolian High School

Private IAOSB Nedim Uysal Vocational and Technical Anatolian High School was

established in 2014 as a vocational and technical school in İzmir Atatürk Organized Industrial Zone with the support of our holding company. The main objective of the school is to train competent engineer candidates in the fields of industrial automation, electrical-electronics, and machinery technologies.

Students are trained in workshops, laboratories and classrooms equipped with technology, providing them with the necessary opportunities to acquire qualified skills in these fields. The school supports students with an education



approach that is qualified for the professions of the future and in line with the requirements of the age.

In order to encourage talented and enthusiastic students to study in this field, 100% scholarships are offered to students. The aim is to enable talented young people to benefit from educational opportunities regardless of their financial means.

Private IAOSB Nedim Uysal Vocational and Technical Anatolian High School makes an important contribution to developing the potential of young people in the fields of technology and industry, in line with Norm Holding's mission of adding value to society and supporting qualified education.

### Norm Vocational Training Center

Norm Vocational Training Center was established in Izmir and Salihli in 2007 and 2015. It aims to train qualified manpower for the sector and provide vocational skills to young people who cannot continue

their education.

Norm Vocational Training Center provides apprenticeship training to students, contributing to their personal development as well as technical knowledge and skills. A total of 186 students have graduated from these centers so far. 109 of them are still working within Norm Holding. In 2022, a total of 141 students were enrolled in the centers, where the development of students is closely monitored, and in addition to the existing curriculum, additional programs in technical and personal development areas contribute to their development.

This is an important ratio that shows the strong cooperation between Norm Holding and training centers and the success of quality education.

The Center's training programs are constantly updated in accordance with the needs of the students and enriched with programs that support their personal

## 109 out of 186 graduates of Norm Vocational Training Center work at Norm Holding

development as well as their skills in technical fields.

### Supporting Children's Education Together with Turkish Education Foundation

Norm Holding was one of the main supporters of the Şevval Sam concert organized by the Turkish Education Foundation (TEV), one of Turkey's most important non-governmental organizations in the field of education, on the occasion of its 55th anniversary. On Wednesday, June 22, all proceeds from the concert held at Çeşme Open Air Theater were used for the education of children and young people. Norm Holding is very proud to have contributed to a better education for future generations with this meaningful organization.

# Social Activities

## NORM sanat

Since 2003, Norm Art, which has made a name for itself with its support for art in Atatürk Organized Industrial Zone, has contributed to the development of art by hosting more than 150 exhibitions to date. In line with its aim of adding value to society, it organizes art education courses for adults and supports the personal and artistic development of individuals interested in art by providing technical and practical training opportunities.

As of 2019, Norm Sanat has signed a commitment to support contemporary dance as well as plastic arts. With the awareness of supporting young talents who will shape the future of art, it organizes contemporary dance workshops and allows young dancers to

express themselves and discover their creativity. On September 26, 2023, she is conducting workshops for the Feminine Contemporary Dance Project, which will be staged for the first time within the scope of the 30th Izmir European Jazz Festival, choreographed by Cansu Ergin and General Artistic Director by Duygu Uysal Simrooğlu.

## Norm Sanat'ta Kurslar Başladı

Norm Sanat'ta dersler 3 Ekim'de yeniden başladı. Desen, yağlı boya, akrilik boya ve linol baskı derslerimiz her Pazartesi ve Salı 11:00-17:00 saatleri arasında gerçekleşiyor.

NORM sanat

Oya



# PERFORMANCE INDICATORS

## Environmental Performance Indicators

### Social Performance Indicators

## Environmental Performance Indicators

Renewable Energy Production Amount (kwh)	2021		2022	
Total	1.767.188,59		3.176.600,58	
<b>Natural Gas Consumption (MWh)</b>				
Natural Gas Consumption	144.591	197.290	195.790	
<b>Electricity Consumption (MWh)</b>				
Electricity Consumption	69.092,61	97.456,6	108.691,20	

\*Yurt dışı lokasyonlar hesaba alınmamıştır.

Greenhouse Gas Emissions (CO <sub>2</sub> e/ton production)	Scope 1		Scope 2	
Norm Fasteners Bolts İzmir	11460,98	11078,96	6719,31	7238,71
Norm Fasteners Bolts Salihli	12703,07	13131,30	8603,21	10716,21
Norm Fasteners Screws	2544,39	3269,57	3264,86	3893,68
Norm Fasteners Nuts	6148,10	5582,29	6895,55	6932,55
Norm Coating	3997,16	4433,05	14279,42	16586,73
Norm Tooling	222,79	183,56	1019,07	1425,25
Norm Fasteners Bursa	42,15	37,43	18,45	19,89
NRM	29,21	28,56	93,75	122,87
STD	560,38	537,20	193,03	208,95
<b>Total (domestic)</b>	<b>37.708,23</b>	<b>38.281,92</b>	<b>41.086,64</b>	<b>47.144,84</b>

Carbon Intensity (scope 1&2 tons CO <sub>2</sub> e /ton production)	2021		2022	
Norm Fasteners Bolts	0,45		0,46	
Norm Fasteners Screws	0,53		0,61	
Norm Fasteners Nuts	0,32		0,32	
Norm Coating	0,06		0,07	

Water Consumption (m <sup>3</sup> )	Total Water Consumption (m <sup>3</sup> )	Artesian water quantity (m <sup>3</sup> )			Amount of Waste Water (m <sup>3</sup> )	
		2022	2021	2020	2020	2021
2020	609.370				2020	563.164
2021	674.668	149.045	71.028	69.260	2021	660.383
2022	780.447				2022	620.158

## Social Performance Indicators GRI: 102-41

Employees by Category	2020		2021		2022	
	Female	Male	Female	Male	Female	Male
Total number of employee	234	283	283	3.063	345	3489
Number of white-collar employees	194	240	240	468	290	523
Number of blue-collar employees	40	43	43	2.595	55	2966

According to Duration of Employment	2020		2021		2022	
	Full-time	Part-time	Full-time	Part-time	Full-time	Part-time
Number of employees by working hours	2718	0	3346	0	3831	3
Number of office employees	609	0	708	0	810	3
Number of field employees	2109	0	2.638	0	3021	0

Number of Employees by Age	2020		2021		2022	
	Female	Male	Female	Male	Female	Male
Under 30 Y.O.years old	42	687	65	1191	101	1426
30-50 years old (including 30 and 50 years old)	182	1709	209	1795	219	1924
Over 50 years old	10	88	9	77	10	80

Number of New Employees Recruited During the Year	2020		2021		2022	
	Female	Male	Female	Male	Female	Male
	28	357	75	805	92	785

Social Performance Indicators

Number of Employees in R&D, Innovation and Digitalization Departments	2020		2021		2022	
	Female	Male	Female	Male	Female	Male
	15	65	27	86	47	117

Subcontracted Worker	2020		2021		2022	
	Female	Male	Female	Male	Female	Male
	Number of subcontracted workers by gender	47	73	58	91	58
	Full-time	Part-time	Full-time	Part-time	Full-time	Part-time
Number of subcontracted workers by duration of employment	120	0	149	0	163	0

Performance Evaluation	2020		2021		2022	
	Female	Male	Female	Male	Female	Male
	Total number of employees subjected to regular performance and career development reviews	234	2484	283	3063	342

Diversity And Equality In Opportunity	2020		2021		2022	
	Female	Male	Female	Male	Female	Male
	Employees in Managerial Positions	0	1	0	0	1
Under 30 Y.O	0	1	0	0	1	0
30-50 years old (including 30 and 50 years old)	21	101	36	111	41	111
Over 50 years old	1	21	2	15	3	20
Number of Female and Male Employees on the Board of Directors	1	5	1	5	1	5
Number of disabled employees by gender	10	50	13	56	15	74

Social Performance Indicators

Employment	2020		2021		2022	
	Female	Male	Female	Male	Female	Male

Employee Turnover						
Total number of employees leaving their jobs	28	201	27	350	53	358

Employee turnover rate calculated by including employees leaving their jobs voluntarily	0,60%	5,60%	0,50%	7%	0,11	0,07
---	-------	-------	-------	----	------	------

Number of positions filled with internal candidates	7	17	14	41	8	62
---	---	----	----	----	---	----

Number Of Employees By Years	Female	Male	Female	Male	Female	Male
------------------------------	--------	------	--------	------	--------	------

Number of employees for 0-5 years	139	1331	168	1.840	223	1960
-----------------------------------	-----	------	-----	-------	-----	------

Number of employees with 0-5 years of service	56	833	80	861	88	1146
---	----	-----	----	-----	----	------

Number of employees with 10 or more years of service	39	320	35	362	45	430
--	----	-----	----	-----	----	-----

Maternity/Parental Leave	Female	Male	Female	Male	Female	Male
--------------------------	--------	------	--------	------	--------	------

Number of employees benefiting from maternity/parental leave	3	107	10	124	16	261
--	---	-----	----	-----	----	-----

Number of employees returning to work after the end of maternity/parental leave	3	106	9	124	13	225
---	---	-----	---	-----	----	-----

OHS TRAINING (hours)	2020	2021	2022
----------------------	------	------	------

Total OHS training	14.561	26.196	42.654
--------------------	--------	--------	--------

Average annual OHS training per employee	5,74	8,55	11,12
--	------	------	-------

GRI 2: General Disclosures 2021

GRI Standard	Disclosure	Explanation	Page no.
GRI 2: General Disclosures 2021	2-1 Organizational Details	About Norm Holding	12-17
	2-2 Entities included in the organization's sustainability reporting	About the Report	5
	2-3 Reporting period, frequency and contact point	About the Report	5
	2-4 Restatements of information	No information is held	-
	2-5 External assurance	No external audit was received within the scope of the report.	-
	2-6 Activities, value chain and other business relationships	About Norm Holding, Message from the Head of Industry Group , Message from the Head of Trade Group, Other Areas of Activity	12-17 32-37 38-41 42-44
	2-7 Employees	Equal Opportunity and Diversity Social Performance Indicators	110-111, 127-128
	2-8 Workers who are not employees	Social Performance Indicators	127-128
	2-9 Governance structure and composition	Corporate Governance Sustainability Management	18-27, 56-71
	2-10 Nomination and selection of the highest governance body	Restraint Norm Holding does not share this information publicly in accordance with the institution's privacy policies.	-
	2-11 Chair of the highest governance body	Structure of the Board of Directors	19-22
	2-12 Role of the highest governance body in overseeing the management of impacts	Sustainability Management	56-71
	2-13 Delegation of responsibility for managing impacts	Sustainability Management	56-71
	2-14 Role of the highest governance body in sustainability reporting	Sustainability Management	56-71
	2-15 Conflicts of interest	Ethics and Compliance	30-31

GRI 2: General Disclosures 2021

GRI Standard	Disclosure	Explanation	Page no.
GRI 2: General Disclosures 2021	2-16 Communication of critical concerns	Risk and Opportunity Management	28-29
	2-17 Collective knowledge of the highest governance body	Structure of the Board of Directors	19-22
	2-18 Evaluation of the performance of the highest governance body	Restraint Norm Holding does not share this information publicly in accordance with the institution's privacy policies.	-
	2-19 Remuneration policies	Restraint Norm Holding does not share this information publicly in accordance with the institution's privacy policies.	-
	2-20 Process to determine remuneration	Remuneration and Nomination Committee Talent and Competency Management	"25, 112-119"
	2-21 Annual total compensation ratio	Restraint Norm Holding does not share this information publicly in accordance with the institution's privacy policies.	-
	2-22 Statement on sustainable development strategy	The Foundations of Our Sustainability Approach	56-58
	2-23 Policy commitments	<a href="https://normholding.com/en/corporate-governance-policies/">https://normholding.com/en/corporate-governance-policies/</a>	-
	2-24 Embedding policy commitments	<a href="https://normholding.com/en/corporate-governance-policies/">https://normholding.com/en/corporate-governance-policies/</a>	-
	2-25 Processes to remediate negative impacts	Risk and Opportunity Management Ethics and Compliance Anti-Bribery and Anti-Corruption Management Sustainability Priorities Goals	"28-29 30-31 30 62-63 66-71"
	2-26 Mechanisms for seeking advice and raising concerns	Ethics and Compliance	30-31
	2-27 Compliance with laws and regulations	Ethics and Compliance	30-31
	2-28 Membership associations	Collaborations and Initiatives	54
	2-29 Approach to stakeholder engagement	Stakeholder Relations	55
	2-30 Collective bargaining agreements	Norm Holding does not have a workforce covered by a collective agreement.	-

## PRIORITY ISSUES

GRI Standard	Disclosure	Explanation	Page no.
<b>GRI 3: Material Topics 2021</b>	3-1 Process to determine material topics	Sustainability Priorities	62-63
	3-2 List of material topics	Sustainability Priorities	62-63
	3-3 Management of material topics	The Foundations of Our Sustainability Approach Sustainability Management Goals	56-58 56-71 66-71

## Climate Change and Energy Consumption

<b>GRI 3: Material Topics 2021</b>	3-3 Management of material topics	Energy and Emission Management	87-89
<b>GRI 302: Energy 2016</b>	302-1 Energy consumption within the organization	Energy and Emission Management	87-89
	302-4 Reduction of energy consumption	Energy and Emission Management	87-89
	302-5 Reductions in energy requirements of products and services	Energy and Emission Management	87-89
<b>GRI 305: Emissions 2016</b>	305-1 Direct (Scope 1) GHG emissions	Environmental Performance Indicators	127
	305-2 Energy indirect (Scope 2) GHG emissions	Environmental Performance Indicators	127
	305-4 GHG emissions intensity	Environmental Performance Indicators	127
	305-5 Reduction of GHG emissions	Environmental Performance Indicators	127

## PRIORITY ISSUES

GRI Standard	Disclosure	Explanation	Page no.
<b>Product Safety and Quality</b>			
<b>GRI 3: Material Topics 2021</b>	3-3 Management of material topics	Product Safety and Quality	77-78
<b>R&amp;D and Innovation</b>			
<b>GRI 3: Material Topics 2021</b>	3-3 Management of material topics	R&D and Innovation	95-102
<b>Operational Excellence and Efficiency</b>			
<b>GRI 3: Material Topics 2021</b>	3-3 Management of material topics	Operational Excellenc	94-96
<b>Occupational Health and Safety</b>			
<b>GRI 3: Material Topics 2021</b>	3-3 Management of material topics	Occupational Health and Safety	120-121
<b>GRI 403: Occupational Health and Safety 2018</b>	403-1 Occupational health and safety management system	Occupational Health and Safety	120-121
	403-2 Hazard identification, risk assessment, and incident investigation	Occupational Health and Safety	120-121
	403-5 Worker training on occupational health and safety	Social Performance Indicators	127-128
	403-7 Prevention and mitigation of occupational health and safety impacts directly linked by business relationships	Occupational Health and Safety	120-121

## PRIORITY ISSUES

GRI Standard	Disclosure	Explanation	Page no.
<b>Talent and Competency Management</b>			
<b>GRI 3: Material Topics 2021</b>	3-3 Management of material topics	"Talent and Competency Management Employee Loyalty"	"112-119 118-119"
<b>GRI 401: Employment 2016</b>	401-1 New employee hires and employee turnover	Social Performance Indicators	127-128
	401-3 Parental leave	Social Performance Indicators	127-128
<b>GRI 404: Training and Education 2016</b>	404-1 Average hours of training per year per employee	Talent and Competency Management	113
	404-2 Programs for upgrading employee skills and transition assistance programs	Training and Programs	114-117
	404-3 Percentage of employees receiving regular performance and career development reviews	Performance Management System	118-119
<b>Digitalization and Automation</b>			
<b>GRI 3: Material Topics 2021</b>	3-3 Management of material topics	Digitalization	103-107
<b>Water and Waste Management</b>			
<b>GRI 3: Material Topics 2021</b>	3-3 Management of material topics	Water and Waste Management	90-91
<b>GRI 306: Waste 2020</b>	306-1 Waste generation and significant waste-related impacts	Water and Waste Management	90-91

## PRIORITY ISSUES

GRI Standard	Disclosure	Explanation	Page no.
<b>GRI 306: Waste 2020</b>	306-2 Management of significant waste-related impacts	Water and Waste Management	90-91
	306-3 Waste generated	Environmental Performance Indicators	127
<b>GRI 303: Water and Effluents 2018</b>	303-1 Water management	Water and Waste Management	90-91
<b>Customer Expectations and Satisfaction</b>			
<b>GRI 3: Material Topics 2021</b>	3-3 Management of material topics	Customer Expectations and Satisfaction	75-76
<b>Responsible Investments</b>			
<b>GRI 3: Material Topics 2021</b>	3-3 Management of material topics	Economic Performance Responsible Investments	17 74
<b>GRI 201: Economic Performance 2016</b>	201-1 Üretilen ve dağıtılan direk ekonomik değer	Economic Performance	17
	201-2 İklim değişikliğinin mali yansımaları ve diğer risk ve fırsatlar	Economic Performance Risk and Opportunity Management	17 28-29
<b>Corporate Governance</b>			
<b>GRI 3: Material Topics 2021</b>	3-3 Management of material topics	Corporate Governance	18-27



[www.normholding.com](http://www.normholding.com)

